

Thrane & Thrane A/S

Capsat[®] Fleet33

TT-3088A

User Manual

Copyright[©] Thrane & Thrane A/S

ALL RIGHTS RESERVED

Information in this document is subject to change without notice and does not represent a commitment on the part of Thrane & Thrane A/S. It is recommended to download the latest version of the manual from the Thrane Extra net or request this from the distributor.

© 2004 Thrane & Thrane A/S. All rights reserved. Printed in Denmark.

Trademark Acknowledgements:

WinPoET is a trademark of iVasion, a RouterWare Company.

Document No: TT98-120086-A.

Release date: 15 April 2004.

Safety Summary

The following general safety precautions must be observed during all phases of operation, service and repair of this equipment. Failure to comply with these precautions or with specific warnings elsewhere in this manual violates safety standards of design, manufacture and intended use of the equipment. Thrane & Thrane A/S assumes no liability for the customer's failure to comply with these requirements.

Microwave Radiation Hazards

During transmission the antenna in this system radiates Microwave Power. This radiation may be hazardous if exposed directly to humans, close to the antenna. During transmission, make sure that nobody gets closer than the recommended minimum safety distance. The minimum safety distance to the antenna on the focal line is 1.3 m.

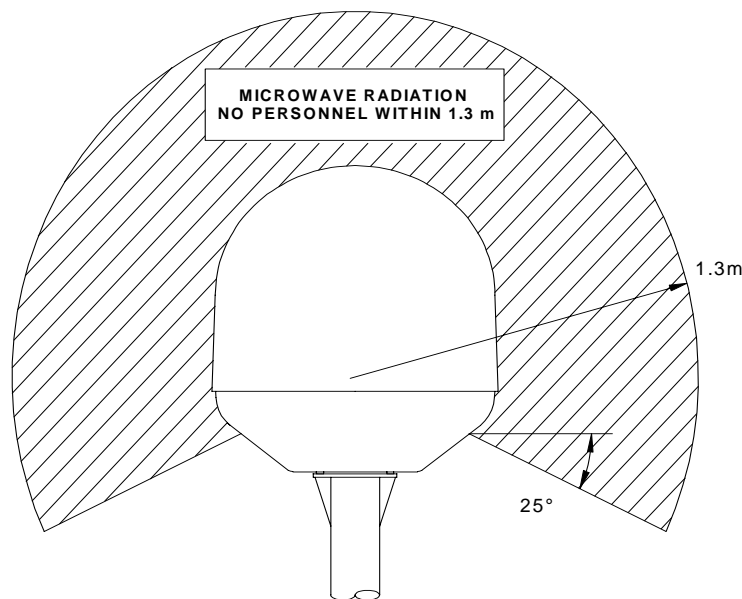

GROUND THE EQUIPMENT

To minimize shock hazard, the equipment chassis and cabinet must be connected to an electrical ground.

DO NOT OPERATE IN AN EXPLOSIVE ATMOSPHERE

Do not operate the equipment in the presence of flammable gases or fumes. Operation of any electrical equipment in such an environment constitutes a definite safety hazard.

KEEP AWAY FROM LIVE CIRCUITS

Operating personnel must not remove equipment covers. Component replacement and internal adjustment must be made by qualified maintenance personnel. Do not replace components with the power cable connected. Under certain conditions, dangerous voltages may exist even with the power cable removed. To avoid injuries, always disconnect power and discharge circuits before touching them.

DO NOT SERVICE OR ADJUST ALONE

Do not attempt internal service or adjustments unless another person, capable of rendering first aid resuscitation, is present.

Table of Contents

1	About the Manual.....	1
1.1	Abbreviations.....	1
2	Introduction.....	3
2.1	The Inmarsat Fleet Service.....	3
2.2	The Capsat Fleet33 System.....	6
2.3	Hardware Interfaces.....	8
2.4	The Control Handset.....	11
2.4.1	LCD/LED Section.....	12
2.4.2	Function Section.....	15
2.4.3	Alpha-Numeric Section.....	17
3	Getting Started.....	21
3.1	Get Ready to Make a Call.....	21
3.1.1	How to Power-Up the System.....	21
3.1.2	How to Shut Down the System.....	23
3.2	Use of PIN Codes.....	24
3.3	Normal Calls.....	25
3.3.1	Calling From the TT-3088A.....	25
3.3.2	Calling To the TT-3088A.....	26
3.4	Data Calls.....	27
3.4.1	MPDS Connection.....	27
3.4.2	9600 Data Connection.....	28
4	Operation.....	29
4.1	Call Functions.....	29
4.1.1	Calls Using the Phone Book.....	29
4.1.2	Call From Handset Connected to RJ11.....	29
4.1.3	Fax Calls.....	30
4.1.4	Internal Calls.....	31
4.2	Using the Menu System.....	31
4.3	Menu System – All Users.....	32
4.3.1	Phonebook.....	32

Table of Contents

4.3.2	Area.....	34
4.3.3	LES.....	35
4.3.4	Mailbox	36
4.3.5	Help Desk.....	37
4.3.6	Alarm Log.....	38
4.3.7	Status	39
4.4	Menu System - Super User	41
4.4.1	Mailbox	41
4.4.2	Call Logs	42
4.4.3	Data Setup	44
4.4.4	Contrast	44
4.4.5	Ring Setup.....	45
4.4.6	Key Beep.....	45
4.4.7	Set UTC Time	46
4.4.8	Set UTC Date	46
4.4.9	Language	47
4.4.10	Disclose Pos.	47
4.4.11	Allowed Dial	48
4.4.12	Ph.Book Dial	49
4.4.13	Auto Prefix.....	49
4.4.14	BarServiceIn	50
4.4.15	BarServiceOut	50
4.4.16	LED Dimm	51
4.4.17	Ant.Setup	51
4.4.18	Alarm.....	53
4.4.19	PIN codes	54
4.4.20	Routing	54
4.4.21	RJ11 Volume	56
4.4.22	LES Config	56
5	PC Programs	59
5.1	System Set-up from PC	59
5.2	Set-up Using RS-232	68
5.2.1	Set-up for MPDS.....	68
5.2.2	Set-up for 9600 Data	72
5.3	Set-up using Ethernet/PPPoE.....	75
5.3.1	Windows XP with Built-in PPPoE Client	75

5.3.2	Win2000 with WinPoET™ PPPoE Client	76
6	Troubleshooting	79
6.1	List of Error messages	79
6.1.1	Satellite Network Messages	79
6.1.2	TT-3088A Messages	93
7	Index	97
	Appendix A - Menu Tree	99

Blank page

1 About the Manual

This manual has the following chapters:

Chapter **2 Introduction** - an overview of the Inmarsat Fleet system and its services. Also a brief description of the systems.

Chapter **3 Getting Started** - a description of how to make and receive calls and the use of PIN codes.

Chapter **4 Operation** - a detailed description of the menu system in the terminal.

Chapter **5 PC Programs** - a description on how to use the accompanying configuration PC software (FleetCP).

Chapter **6 Troubleshooting** – a description of the most common errors, how to deal with them and how to get further help if necessary.

Chapter **7 Index** - a subject index

Appendix A - Menu Tree

Appendix B – Coverage map

1.1 Abbreviations

ACU	Antenna Control Unit
ADU	Above Deck Unit
AORE	Atlantic Ocean Region East
AORW	Atlantic Ocean Region West
BDU	Below Deck Unit
FEU	Front End Unit
GPS	Global Positioning System

IMN	Inmarsat Mobile Number
ISDN	Integrated Services Digital Network
ISN	Inmarsat Serial Number
IOR	Indian Ocean Region
ISP	Inmarsat Service Provider
LCD	Liquid Crystal Display
LED	Light Emitting Diode
LES	Land Earth Stations
MES	Mobile Earth Station
MMI	Man Machine Interface
MPDS	Mobile Packet Data Service
MSN	Multiple Subscriber Number
NCS	Network Co-ordination Station
NSR	Network Status Record
PIN	Personal Identification Number
PUK	Personal Unblocking Key
POR	Pacific Ocean Region
PSTN	Public Services Telephone Network
RCC	Rescue Co-ordination Center
STE	Secure Telephone Equipment
T&T	Thrane & Thrane A/S
TNID	Terrestrial Network ID
UDI	Unrestricted Digital Information

2 Introduction

2.1 The Inmarsat Fleet Service

The Inmarsat Fleet service is based on 4 Geo-stationary 3rd generation satellites situated above the equator. Geo-stationary means that the satellites are always located in the same position, i.e. they rotate at the same speed as the earth. Each satellite covers a certain area (footprint) and supports a number of powerful spot-beams making the service available in virtually all ocean regions on the earth between approximately 76°N and 76°S.

The 4 Geo-Stationary Inmarsat Satellites

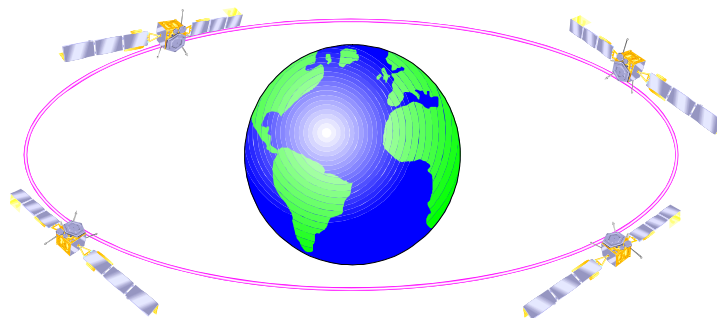

The satellites are your connection to the worldwide networks, and they are managed by the Network Coordination Stations (NCSs), run by Inmarsat. The primary functions of the NCSs are to constantly keep track of which terminals are logged on to the system, and assign a free channel when a call is made.

A Land Earth Station Operator (LESO) runs the gateway between the public network and the satellites. Different operators around the world run the various LES's.

The Fleet services are prepared for operation with the next generation of Inmarsat satellites (Inm-IV) expected in 2005. The services, which allow for a wide range of applications, supported by the Inmarsat Fleet encompasses:

- Circuit switched services:
 - Mini M voice call (Global)
 - 9.6 kbps data (Spot beam only)
 - 9.6 kbps fax (Spot beam only)
- Packet switched services
 - 64/28 kbps MPDS (Spot beam only)

(cf. Appendix B for a map on global and spot beam coverage).

Service explanation:

The **mini-M voice** service is only for voice transmission. The voice transmitted over the satellite is subject to a compression process down to 4.8 kbit/s, which reduces the bandwidth use and subsequently the cost.

The **9.6 kbps fax** service is a service that enables G3 fax machines employing one of the modem standards: V.27 or V.29.

The **9.6 kbps data** service allows you to establish a 9.6 kbps circuit switched data connection employing the modem standard: V.24.

The **MPDS service** is a packet data service where the tariff depends on the amount of data transmitted. This service is a more cost-effective solution for web browsing, and other applications where there is no need for constant transmission of data in both directions. It is also suitable for applications where a constant connection is required, because the user is no longer charged the "per minute

rate". The channel is a shared channel i.e. the transmission speed may be reduced when other users are using the same channel. The channel to be shared among the users has a capacity of 64 kbps in the direction to the terminal, and from the terminal the channel to be shared among the users has a capacity of 28 kbps.

Important notice: Before a terminal can be used on the network, it has to be commissioned by one of the Inmarsat Service Providers (ISP's). In order to use the different Inmarsat Fleet services it is necessary to have at least one Inmarsat Mobile Number (IMN) for each of the above mentioned services. In case all 3 circuit switched services are commissioned on your terminal, you will have 3 IMN numbers.

Calling an Inmarsat Fleet terminal is equal to making international calls. If the satellite region/area is not known for the terminal the "country" code for a terminal is 870. When you dial an Inmarsat Fleet terminal through the public network, you have to dial the IMN number in addition to the international access code for Inmarsat, e.g.:

+870 600 555 555

Making calls from an Inmarsat Fleet terminal is equal to making international calls, as the country code always has to be dialed.

2.2 The Capsat Fleet33 System

The Capsat® Fleet33 System includes the following system components:

- TT-3008G Capsat® Fleet33 Antenna (ADU)
- TT-3038G Capsat® Fleet33 Transceiver Unit (BDU)
- TT-3622E Capsat® Fleet33 Handset Cradle
- TT-3620G Capsat® Fleet33 Control Handset (4 wire)
- Accessories (manual, software, etc.)



Instructions on how to assemble the system, wiring and specification, can be found in the Installation Manual.

TT-3008G Capsat® Fleet33 Antenna

The TT-3008G antenna or ADU (Above Deck Unit) is a stabilized high-gain antenna. The antenna has built-in all functions for satellite tracking including a GPS system.



TT-3038G Capsat® Fleet33 Transceiver Unit (BDU)

All the interface connectors are located on the rear of the Transceiver Unit or BDU (Below Deck Unit).



TT-3622E Capsat® Fleet33 Handset Cradle / TT-3620G Capsat® Fleet33 Control Handset (4 wire)

The Handset is used to configure the system and to make calls. See section 2.4 for a description of buttons, LED's and display of the handset.



2.3 Hardware Interfaces

The Transceiver Unit of the Capsat® Fleet33 has the following hardware interfaces:

- Analogue RJ11 number 1
- Analogue RJ11 number 2
- Control Handset (4 wire)
- Ethernet
- RS-232

- 4 Discrete I/O
- Power Connector

All connectors for these interfaces are found on the rear of the Transceiver Unit.

Two Analogue RJ11 interfaces:



The RJ11 ports as shown above can be used for connection of analogue phones and G3 fax machines.

Selection of service for the interfaces is independent of each other. If the mini-M voice is selected, a phone must be connected as only voice connections can be established.

Cradle/Handset interface:



The transceiver has one 4-wire handset port with RS-485 data control. The Handset can be used to set-up the terminal and it can be used to make or receive phone calls.

Ethernet interface:

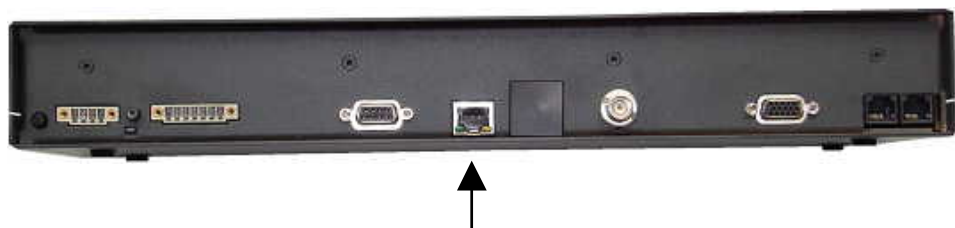

The Ethernet interface is a RJ45 connector. It can be used for the following service types:

- MPDS service
- 9600 Data Service
- Connection of an IP Router

RS-232 interface:



The RS-232 interface is a standard 9-pin serial ports, with a maximum port speed of 115.2 kbps. It can be used for the following service types:

- MPDS service
- 9.6 kbps data
- Configuration of the terminal via FleetCP software
- Connection of a IP Router

When using the FleetCP program, the PC must be connected to the RS-232 interface (see section 5.1).

Discrete I/O interface:



The transceiver also has a discrete I/O interface, containing 4 configurable input/output.

Note: Interface is currently not supported.

Power Connector:

For connection of power, see Installation Manual.

2.4 The Control Handset

The Control Handset is the primary interface for the Capsat® Fleet 33 system. It enables the user to dial numbers, it displays error and status messages, and it is used to configure the transceiver unit.

The Handset is divided into 3 distinct and inter-working sections.

1. The first is the Liquid Crystal Display (LCD) and Light Emitting Diodes (LED) section. This section gives the user visual indications about the operation and status of the system.
2. The second is the Function section. This section enables the user to interact with the software menu system of the transceiver unit.
3. The third is the Alpha-Numeric section. This section enables the user to dial and perform data entry functions into the transceiver unit.

All sections are explained in detail on the following pages.







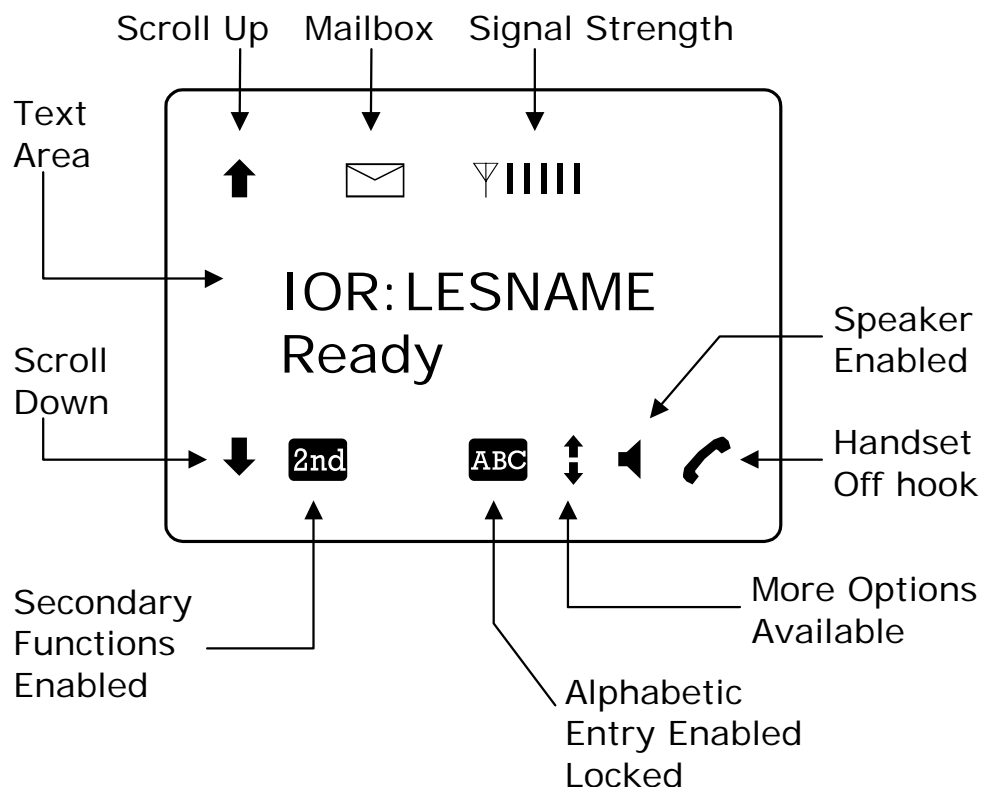







2.4.1 LCD/LED Section



As shown in the picture above, the top of the handset contains the LCD for displaying information to the user. It can be adjusted for contrast and is backlit for viewing in dimly lit areas or night operations. The LCD display is graphically shown below:



The display contains a set of symbols, which together with the 4 indicators situated below the display gives continuous indication of current status.

Symbol	Meaning
	More menu entries above.
	More menu entries below
	Turned on when the  key has been pressed.
	Turned on when the keypad is in alpha mode. Alpha mode is used to enter letters (for example names in the phone book).
	The value in a menu must be selected between certain predefined values by means of the  and  keys.
	The speaker. The user can turn the external speaker on and off by pressing   . The  symbol is displayed in the LCD when on.
	Short message stored at a LES – see section 4.3.4 and 4.4.1 Mailbox for further information.
	The number of bars (I) following this antenna symbol indicates received signal strength. Up to 5 bars. The number of displayed bars may fluctuate during a call. This is due to a power reduction, negotiated between the terminal and the LES.
	The handset is off hook

There are four LED's under the LCD display (see below). From left to right they are Power (GREEN) – Alarm (RED) – Connected (AMBER) – Synchronization (GREEN).

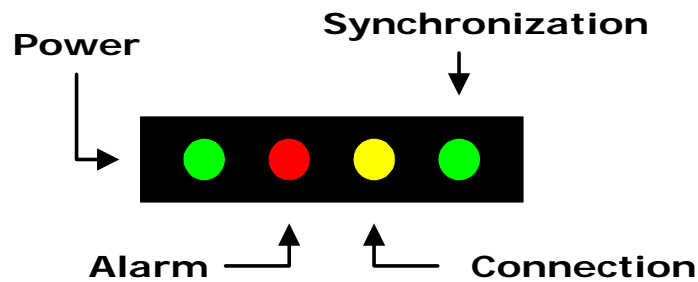

POWER LED (GREEN): The Power LED indicates that the system is powered up.

ALARM LED (RED): The Alarm LED will illuminate when the system detects a fault. An error code will also be displayed in the LCD and in the error log.



CONNECTION LED (AMBER): The Connection LED will flash when a call is ringing at the receiving end and will illuminate steady when a connection is made.





SYNCHRONIZATION LED (GREEN): This is a dual function LED. Initially, the LED will illuminate when the system has synchronization with a satellite. When the system has established a data call, the LED assumes its secondary function as a data transfer light. When data is being transferred (sent or received), the LED will light. This is a quick visual reference during data communications.



2.4.2 Function Section

The Function buttons, as shown above, enables the user to enter the menu system of the transceiver and change various settings. Each button is described in detail below.





Key	Function
	<p>This key has two functions.</p> <ol style="list-style-type: none"> 1) If system is 'ON', this key will either – by a single press - enter the top level of the menu system (see section 4.3 Menu System) or – by holding down for about 5 sec. - power down the system. 2) If system is 'OFF', this key will force the system to power up.
	<p>This use of this key is depending on the present MMI status.</p> <p>In the <u>Menu system</u> this key will exit the current submenu until main level is reached.</p> <p>When <u>asked YES or NO</u> by the system, this key will be interpreted as a 'NO' response.</p> <p>When <u>entering data</u> into the system, this key will cancel the entry.</p>











Key	Function
	<p>This use of this key is depending on the present MMI status.</p> <p>In the <u>Menu system</u> this key will enter the chosen submenu.</p> <p>When <u>asked YES or NO</u> by the system, this key will be interpreted as a 'YES' response.</p> <p>When <u>entering data</u> into the system, this key will accept the entry.</p>
	<p>This key has two functions.</p> <p>The primary function is to <u>clear</u> the last entered character. It is similar in function to the backspace key on a PC.</p> <p>The secondary function is to <u>insert</u> new characters. This is used when inserting new Inmarsat Mobile Numbers (IMN's), Phonebook entries, etc.</p>
	<p>This key has two functions.</p> <p>The primary function is to <u>scroll upwards</u> to menu items not shown on the 2-line display of the LCD.</p> <p>The secondary function is to <u>edit</u> previously entered information.</p>
	<p>This key has two functions.</p> <p>The primary function is <u>toggle</u> between normal mode and alphanumeric mode.</p> <p>The secondary function is to <u>delete</u> previously entered information.</p>
	<p>This key is used to access secondary key functions.</p>

Key	Function
	This key has two functions. The primary function is to <u>scroll downwards</u> to menu items not shown on the 2-line display of the LCD. The secondary function is presently not used.
	This key toggles between 'on hook' and 'off hook'.





2.4.3 Alpha-Numeric Section

The keypad can be in normal (numeric) mode or alpha mode. Normal mode is used to enter digits (phone numbers) whereas alpha mode is used to enter letters (names in the phone book). The  is used to toggle between the two modes. The display indicates if in alpha mode. In alpha mode each of the numeric keys (plus ) can be used to select between subsets of the alphabet (and certain special characters) by pressing the key a number of times until the wanted letter/character is shown on the display. To insert the letter C it is necessary to press  3 times in alpha mode. Below is an overview of the relevant keys in alpha mode.



Key	Toggles between when pressed in alpha mode
	- ? ! , . : ' \$ () + / 1
	A B C 2
	D E F 3
	G H I 4
	J K L 5
	M N O 6
	P Q R S 7
	T U V 8
	W X Y Z 9
	0 or Move cursor (forced)
	<space>

A number of keys have a 2nd function.

Key	Function
 	Recalls the last dialed number.
 	Not used

Key	Function
2nd 3 ^{Area} _{def}	Shortcut to the area selection submenu, see section 4.3.2 A.
2nd 4 ^{Fax} _{ghi}	Used to establish a fax call from the handset if the fax does not have a keypad. See section 4.1.3 Fax Call.
2nd 5 ^R _{jkl}	Not used.
2nd 6 ^{Mute} _{mno}	Toggles the handset microphone 'ON' or 'OFF'.
2nd 8 [↑] _{tuv}	Toggles the cradle speaker 'ON' or 'OFF'.
2nd 9 ^{Ant} _{wxyz}	Shows C/No "signal strength" in the display. Pressing 2nd 9 ^{Ant} _{wxyz} or Exit returns to the previous state.
2nd # ^{Dim}	Sets the brightness of the LED's. See section 4.4.16 below LED Dimm.
2nd 0 ^{Hdesk}	Short cut to the Help desk menu. See section 4.3.5 below Help Desk.
2nd C ^{Ins}	Insert an entry (for example in phone book)
2nd ↑ ^{Edit}	Edit an existing entry (for example in phone book)
2nd A ^{Del} B C	Delete an existing entry (for example in phone book)
2nd ↓ ^{Audio}	Not used.

Blank page

3 Getting Started

3.1 Get Ready to Make a Call

3.1.1 How to Power-Up the System.

There are two ways to power up the system:

- Power Key on handset
- Power Button on back panel of Transceiver Unit

The handset power button is also the menu button. To power up you may simply press the button once.

The transceiver power button is placed on the back panel of the unit. See figure below.



Press and hold the power button for a few seconds until the green LED on the front of the terminal lights up.



3

The display and all LED's on the handset and the cradle will light up for a few seconds.

Below is a view of the normal handset display readout, while the System is booting.

Initialising

▽
**AORE:
Wait for NCS**

▽IIIIII
**AORE:
Wait for NCS**



The system may stay in the "Wait for GPS" state for an extended period, if e.g. the antenna has been turned off for a long time or there is not a free view to the GPS satellites. The time to get the GPS position may be several minutes.

When the display reads "READY" as shown above, the system is ready to make and receive calls.

3

3.1.2 How to Shut Down the System.

Note: To make sure that writing to the configuration module is completed, please wait at least 10 seconds after any changes to the configuration, before shutting the system down.

To shut down the system from the handset, you press the  button for 3 sec. The display now shows that if you press the key for further 4 sec the terminal will power down. The display counts down to zero, but by releasing the button any time before it reaches zero, you may abort the power down procedure.

To shut down the system from the transceiver press and hold the power button for a few seconds, until the handset display shows the message shown below.

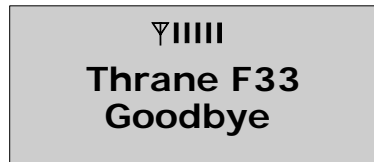

Let go of the button and the system will shut down.

Note: After a shut down please wait at least 5 seconds, before trying to power up the system again.

3

3.2 Use of PIN Codes.

Access to some terminal functionality is restricted by PIN codes. Two different kinds of User PIN codes are used by the system: One PIN for the Super User and one for the Service User.

For both PIN types the length must be between 4 and 8 digits and they must contain digits between 0 and 9.

The normal everyday user (**Normal User**) can make and receive calls, access the phonebook, chose an ocean region and a default LES, read the alarm log and status and make calls from the Helpdesk. For a description of these functions refer to section 4.3 "Menu System". All other functionality has to be carried out by a Super User or a Service User.

Super User

The Super User has the same rights as the Normal User. In addition the Super User can access the Super User menu (see section 4.4 for details). A Super User will typically be a person responsible for setting up and maintaining the system. It is only possible to have one Super User PIN

code. If the code is entered incorrectly 5 times, the PIN becomes blocked. A blocked Super User PIN can only be unblocked by a PUK code or the Service User. The factory PIN code is '12345678'.

Service User PIN

The Service User has access to all functionality in the Fleet system, which is accessible through the handset. Only T&T and/or the supplier of the equipment will normally know this PIN. If the PIN is entered incorrectly 5 times, the PIN becomes blocked. Only a PUK code can unblock a blocked Service User PIN. Refer to the "TT-3088A Capsat Fleet33 Installation Manual" for the use of the service menu.















3.3 Normal Calls

3.3.1 Calling From the TT-3088A

When making calls from a handset or from a fax keypad just type in the phone number as if you were making an international call (with prefix for automatic international calls equal to 00).

Example:

To dial the number of Thrane & Thrane (+45 39558800), press:

-   for international calls
-   for country code then
-         followed by
-  or .

The display on the terminal handset will show how the call proceeds.

You hang up by pressing . After hanging up, the display will show how long the call lasted.

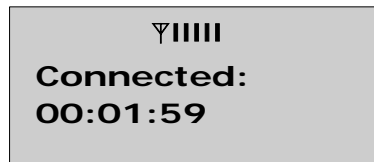

The Phone Book can also be used to initiate a call, either by selecting an entry in the phone book or by using the short code. See section 4.1.1 for details.

3

3.3.2 Calling To the TT-3088A

Calling the terminal or a device connected to the terminal is similar to making international calls. The specific IMN-number (a terminal may have more numbers as different services exist and more devices may be connected to the different hardware interfaces of the terminal) has to be preceded by one of the five possible international access codes. This depends on whether you know which area the terminal is within or not:

870: Area of terminal not known
(Requires that the LES support Mobility Management).

871: AORE
872: POR
873: IOR
874: AORW

To call a terminal positioned in IOR dial:

00873 followed by the IMN number.

3.4 Data Calls

3.4.1 MPDS Connection

The Mobile Packet Data Service (MPDS) provides the mobile user with an economic and flexible data connection. The user is only charged by the transferred traffic (in MB). This means that for applications like Web browsing, email services, IP/LAN connectivity, small to medium size file transfer, the MPDS will be the most economic and convenient solution. The maximum data transfer rate is 64 kbit/s to the terminal and 28 kbps from the terminal.

A connection can be started automatically by an application like Internet Explorer or Outlook Express. The connection can also be established manually. In windows, open Dial-Up networking and double click the appropriate icon. Enter username and password if necessary. Click 'Connect'. Wait for the connection to be completed, indicated by a 'Dial-up Networking' icon in the task bar tray.

To disconnect: Right click the tray icon and choose 'Disconnect'.

See section 5.2.1 on how to setup the computer and transceiver for an MPDS connection.

Please note that while in MPDS mode the TT-3088A is flagged busy in the Inmarsat network, i.e. it is not able to receive any calls, until it returns to normal idle mode. However you may have a "Call Waiting Notification" if the terminal is configured for the feature and supported by your service provider.

3.4.2 9600 Data Connection

9.6 kbps data is a circuit switched service, i.e. you have the 9.6 kbps speed all the time, and you pay for the time you are connected. This service will be the most economic solution for batch data transfers.

The connection can be established manually. In windows, open Dial-Up networking and double click the appropriate icon. Enter username and password if necessary. Click 'Connect'. Wait for the connection to be completed, indicated by a 'Dial-up Networking' icon in the task bar tray.













To disconnect: Right click the tray icon and choose 'Disconnect'.

See section 5.2.2 on how to setup the computer and transceiver for a 9.6 kbps data connection.

4 Operation

4.1 Call Functions













4.1.1 Calls Using the Phone Book

The phone book can be used to initiate calls, either by selecting an entry in the phone book, and then pressing  or  ^{Dim}, or by using the short code. The latter is done by pressing  followed by the short code. Pressing  afterwards will establish the call. Pressing  ^{Dim} instead will show the actual number and the call can then be established by pressing  or  ^{Dim}. Short code 0 contains the last dialed number, thus  ^{Hdesk}  ^{Dim} or   ^{Redial} followed by  will redial the last number.

4.1.2 Call From Handset Connected to RJ11

Making a call from a (normal 2-wire PSTN) phone connected to one of the two analogue RJ11 interfaces is done in the same way as a call from the handset. Just keep in mind to press the  key in order to signal the terminal, that the number is complete.

To Call Thrane & Thrane in Denmark (country code 45) is done by pressing the following keys on the phone:

When using one of the RJ11 analogue interfaces please make sure that the selected interface is configured for a

service, which supports voice (mini-M voice, speech or 3.1 kHz audio). See section 4.4.20. **Routing**

The display on the handset will show how the call proceeds.

After hanging up (on the 2-wire phone), the display will show how long the call lasted.

4.1.3 Fax Calls

Fax calls can be made whether or not the fax has got a keypad.

Making calls from a fax (with keypad) connected to one of the two analogue RJ11 interfaces are done as international calls followed by [#]. Calling Thrane & Thrane in Denmark (country code 45) press the following keys on the fax:

[0] [0] [4] [5] [3] [9] [5] [5] [8] [8] [0] [0] [#]

Please make sure that the selected analogue RJ11 interface is configured for a service, which supports fax.

The display on the handset will show how the call proceeds.

After hanging up, the display will show how long the call lasted.

To make fax calls when the fax has not got a keypad is done by using the keypad on the terminal in the following way. Calling Thrane & Thrane in Denmark (country code 45) press the following keys on the Capsat® Fleet Handset:

[0] ^Hidesk [0] ^Hidesk [4] ^{Fax}ghi [5] ^Rjkl [3] ^Area def [9] ^{Ant}wxyz [5] ^Rjkl [5] ^Rjkl [8] [↑]tuv [8] [↑]tuv [8] [↑]tuv [8] [↑]tuv [2nd] [4] ^{Fax}ghi

Then press the start-button on the fax.

To hang up after faxing please refer to fax user manual.

4.1.4 Internal Calls

It is possible to make internal calls between the RJ11 (2 wire) interface. To initiate a call press the interface code from the table below and then .

Interface	Interface Code	Interface port
RJ11 #1	2	X1
RJ11 #2	3	X2

4.2 Using the Menu System

The level of access to the menus is divided into 3 groups of users. A Normal User, a Super User and a Service User.

The Normal User has access to normal everyday functions. The Super User has the same rights, but can additionally access different setup menus. The Service User menu is only accessible to the supplier or Thrane & Thrane. Both Super User and Service User menus are protected by PIN codes.



To access the menu system press: .

To scroll through menus use the keys  *Edit* and  *Audio*.

To enter a submenu press: .

To exit to a previous level press: .

An entry in the menu system can also be reached by pressing  and a number corresponding to the entry

level, e.g. pressing   will access the 'Helpdesk' menu.

The complete menu tree can be found in Appendix A - Menu Tree.

4.3 Menu System – All Users

This section describes the functions in the menu system available to all users.

4.3.1 Phonebook

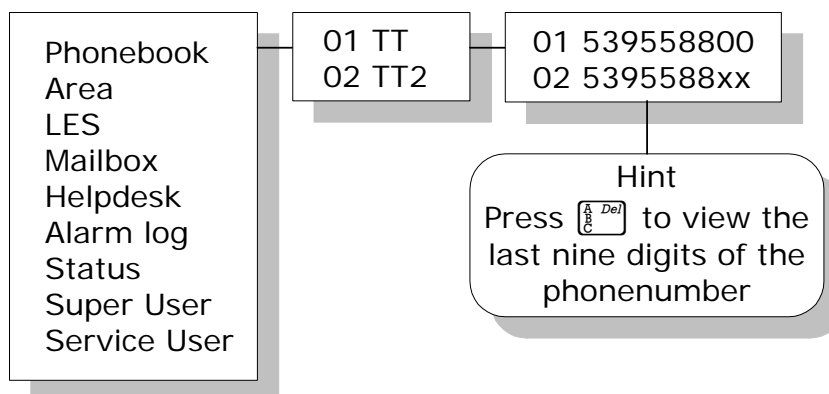

The terminal **PhoneBook** contains 99 entries. Each entry contains the following information:

- Name
- Telephone number
- Short code

The telephone number includes call prefix for automatic calls and international access code. The telephone number can hold up to 22 digits.

The name can hold from 0 to 16 characters.

The short code can be used for quick access when dialing. To use the short code, press ***** <short code> **#^{Dim}** and press **#^{Dim}** again to dial.

The list of entries in the phone book is sorted according to short code.

An entry in the phone book is displayed as a short code and a name if in alpha mode or as a short code and a telephone number if in normal mode.

Use **↑^{Edit}** **↓^{Audio}** to select an entry and press **OK**. The phone number is displayed.

Press **☎** or **#^{Dim}** to dial.

Inserting an entry in the phone book from within the phone book menu is done in the following way. In this example the number to T&T, 004539558800, with short code 14 is inserted.

2nd **C^{Ins}**
 THRANE **OK**
0^{Hdesk} **0^{Hdesk}** **4^{Fax}** **5^R** **3^{Area}** **9^{Ant}** **5^R** **5^R** **8^{tuv}** **8^{tuv}** **0^{Hdesk}** **0^{Hdesk}**
OK
1^{Redial} **4^{Fax}** **OK**

To edit or delete entries: Select the entry in the phone book and press **2nd** **↑^{Edit}** and **2nd** **⌵^{Del}** respectively.

4.3.2 Area

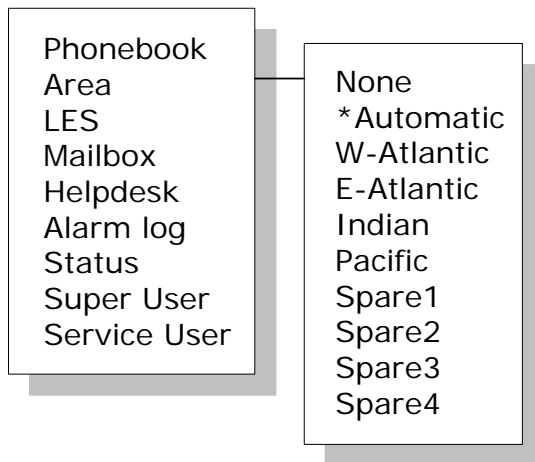

The **Area** menu is used to select satellite/ocean region. The possible options are:

- None (no satellite is selected)
- Automatic (automatic satellite selection)
- W-Atlantic (AOR-W satellite)
- E-Atlantic (AOR-E satellite)
- Indian (IOR satellite)
- Pacific (POR satellite)
- Spare 1 (for future use)
- Spare 2 (for future use)
- Spare 3 (for future use)
- Spare 4 (for future use)

If **Automatic** is selected the system will search through the options and select based on signal strength.

To change the selection: Choose an area and press **OK**. The selection will be marked with an *.

The coverage map can be found in the FleetCP configuration program (see section 5.1 System Set-up from PC).

4.3.3 LES

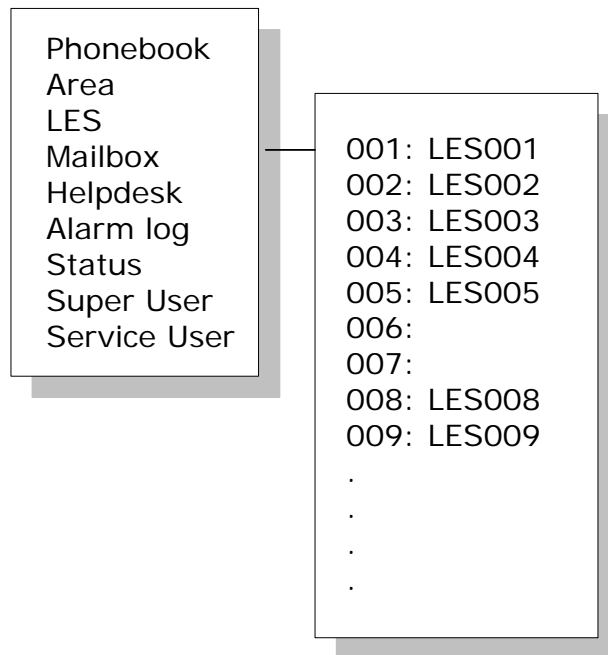

The **LES** list contains a list of those LES operators, which may be selected as gateway to the terrestrial network. The last used LES will be marked with * and this LES will also be the first LES tried next time the terminal is logged on. Use to select. The Area selected in section 4.3.2 A, will decide, which LES's will be available for selection (see section 4.4.22 LES Config for further information about LES configuration).

4.3.4 Mailbox

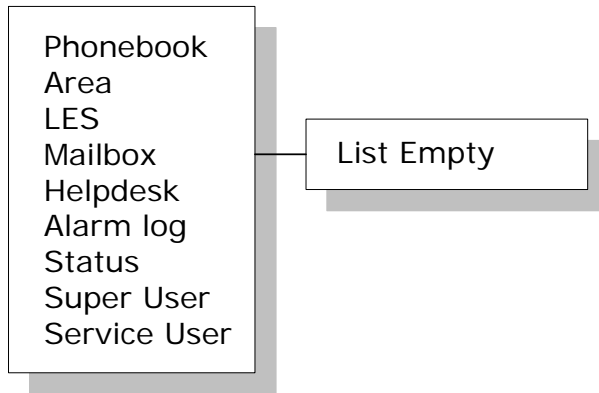

The **Mailbox** feature handles messages being sent from the LES operator. If a call is made to a terminal, which is busy, switched off, etc. the LES operator may offer the facility to record a short message. When the terminal again becomes operational a message is sent indicating that the LES operator has recorded a short message for the terminal.

The  symbol in the handset display indicates the presence of such messages.

Each message can be seen in the **Mailbox** menu and contains the following information:

- LES Access Code
- Service type (voice, fax, data).

To View a entry, select the message and press . See how to delete a message in section 4.4.1 Mailbox.

4.3.5 Help Desk

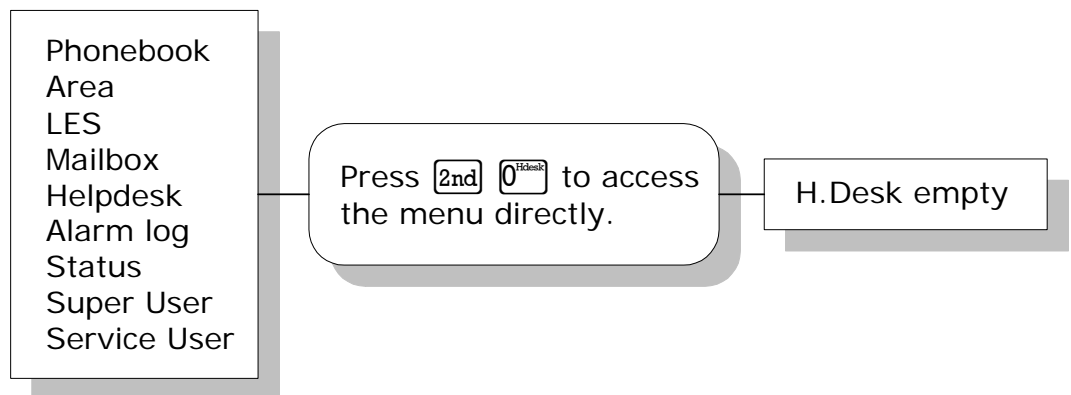



The **Help Desk** menu can be used to select and initiate calls to certain numbers, which may provide help in case you have forgotten your PIN code. Press [2nd] [0^{Hdesk}] to activate.

Editing/inserting and deleting entries is done in exactly the same way as with the phone book, but it can only be done from the service user menu. Normally this menu is only accessible to T&T or the supplier. Each entry contains a phone number, name of the entry, and a LES access code.

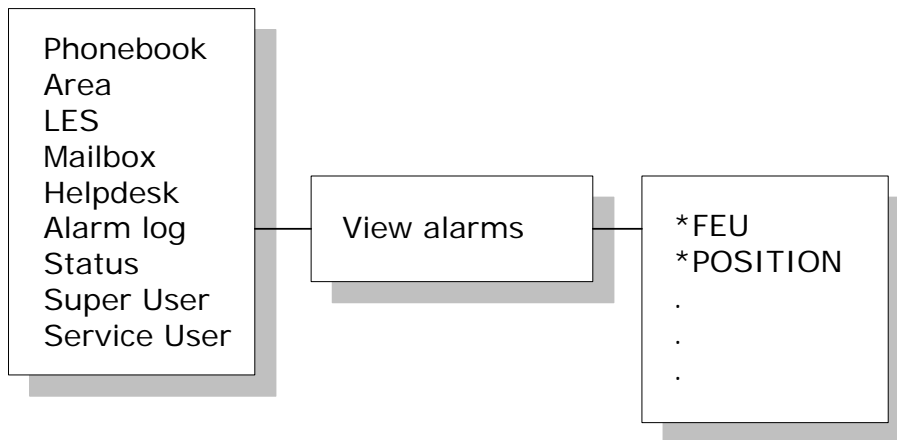
4.3.6 Alarm Log



The **Alarm Log**, logs all the alarms in the system (cf. 6.1 List of Error messages). From this menu, the alarm can be viewed only. To clear the alarm list see section 4.4.18. Scroll through the list, using the   keys. A * in front of the Alarm name, indicates that the alarm is still active. Select an alarm for viewing, by pressing . Each entry for an alarm contains an alarm description and the time and date when the alarm occurred. See section 6.1 for a list of alarms.

The alarm log can contain up to 20 entries. The log will wrap around when the log is full.

4.3.7 Status

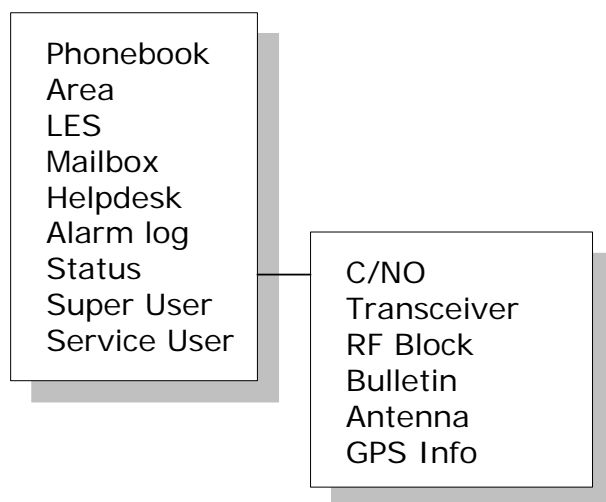

The **Status** menu has got the following sub menus:

- C/No
- Transceiver
- RF block
- Bulletin
- Antenna
- GPS

C/No:

Choosing C/No will display the signal strength in dBHz. Pressing **Exit** will return to the previous state.

Transceiver

Release date:	Software release date.
Unit Type:	Type of unit.
Serial No.:	T&T serial number.
ISN:	Inmarsat serial number.
PCB No.:	Serial number of main CPU board.
Forward ID:	Terminals Forward ID number.
SW Ver.:	Software version.

RF Block

RX Frequency:	Receiving frequency in MHz.
---------------	-----------------------------

TX Frequency:	Transmitting frequency in MHz
Freq. offset:	Frequency offset between 0-1500 Hz.
Acc. offset:	Acc offset between 0-1500 Hz.
AGC:	AGC between 0-1024.
Gain:	Gain between 0-256.
TX level:	TX level equals LOW or OK.
Lo1-Lo3:	Lox In or Out of lock.
Temperature:	Temperature in deg. C.
Power mode:	Power mode in sleep or normal.

Bulletin

Ocean Region:	AORW, AORE, POR or IOR.
NSR state:	Not initialized, initializing or initialized.
Type:	Mini-M or NG
Bulletin page 1-6:	Page 1 to 255 or Invalid.
Spot beam ID:	Spot beam ID number between 1-255.
SU CC Rxed:	Between 0000-9999.
SU CC Txed:	Between 0000-9999.

Antenna

FEU:	Unit type:
	Serial no.:
	SW version:
	Mode:
	Power:
	Temperature:
	Cable loss:
	Alarms:

If cable loss is 100%, it means that the cable loss compensation is at its maximum, and may therefore not be able to compensate fully for the cable loss. A cable with a lower RF loss should be used.

ACU:	Unit type:
	Serial no.:
	State:
	Input power:

SW version:

Alarms:

GPS

PositionInfo: Not ready or Latitude and Longitude.

Heading: Not ready, heading 0-360 degrees or
Heading N/A Low speed (If speed is
equal to or below 1 knot).

Speed: Not ready or speed in knots.

UTC Time: Not ready or YYYY:MM:DD HH:MM:SS

Internal GPS: Not ready or Active and ready.

4.4 Menu System - Super User

4.4.1 Mailbox

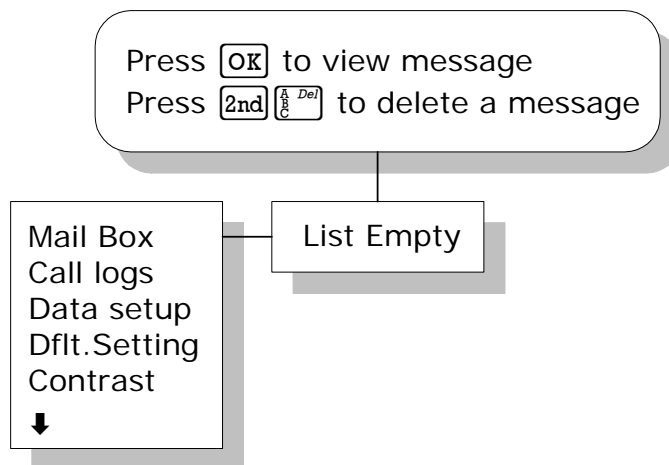

The **Mailbox** feature handles messages being sent from the LES operator. If a call is made to a terminal, which is busy, switched off, etc. the LES operator may offer the facility to record a short message. When the terminal again becomes operational a message is sent indicating that the LES operator has recorded a short message for the terminal.





The  symbol in the handset display indicates the presence of such messages.

Each message can be seen in the **Mailbox** menu and contains the following information:

- LES Access Code
- Service type (voice, fax, data).

The following operations are possible:

- View entries
- Delete entries.

To View an entry, select the message and press . To delete an entry, select the message and press   .

4

4.4.2 Call Logs

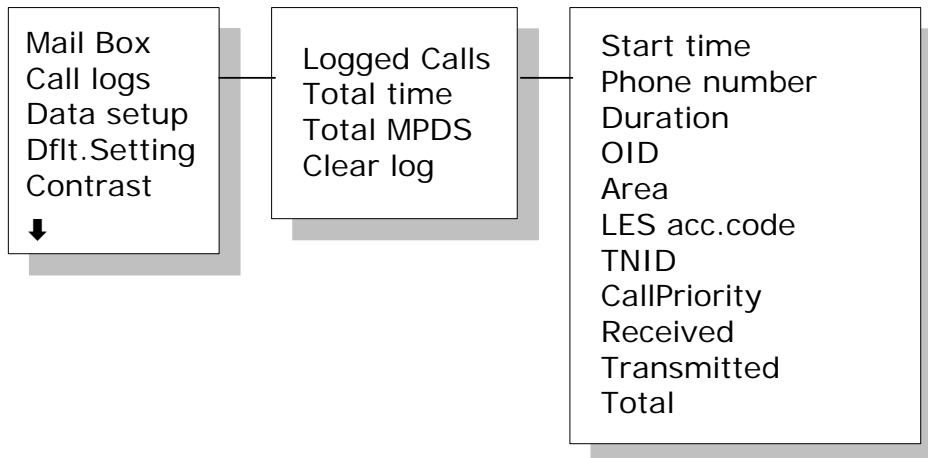

The **Call log** menu has got the following sub-menus

- Logged calls
- Total Time
- Total MPDS
- Clear log

By entering the **Logged calls** menu it is possible to inspect information about each of the outgoing calls made on the terminal. The following information is logged for each call:

- Start time of call.
- Destination phone number.
- Duration of call
- Originating ID. (Description of service used).
- Ocean region used.
- LES access code.
- Terrestrial network identity (always 0).
- Call priority.
- Number of received bytes in MPDS.
- Number of transmitted bytes in MPDS.
- Total number of bytes in MPDS.

Total Time shows the total accumulated call time since last reset.

Total MPDS shows the total accumulated number of bytes, used in MPDS sessions.

To clear the Call Log select the **Clear Log** menu. Press **OK** to clear or **Exit** to abort.

The call log can contain up to 100 entries. After that it will do a wrap around and start overwriting the oldest entry.

A warning will be generated when the call log contains more than 70 entries. You may then back up your log data by Fleet CP PC software. If you also clear the log, you will get a warning again when 30 entries are left.

4.4.3 Data Setup

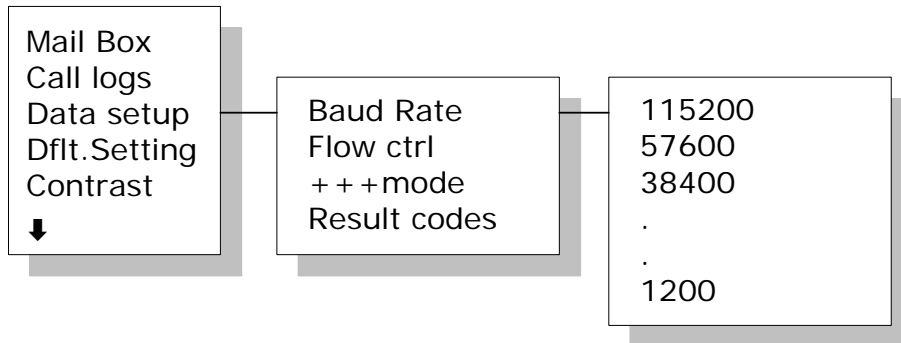

This menu is used to setup baud rate and dataflow control for the RS-232 interface. The following settings can be configured.

Baud Rate: 115200-1200
Flow Ctrl: None | Xon/Xoff | Hardware
+++mode: Disabled | Enabled
Result codes: Disabled | Enabled

4

4.4.4 Contrast

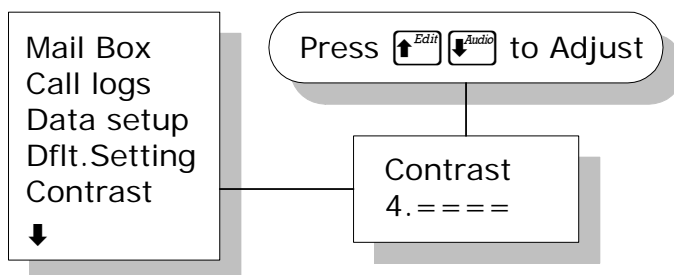

The display contrast of the handset can be adjusted. To change the contrast level, select the **Contrast** menu and adjust the value with **[Edit]** and **[Aurio]**. Setting can be adjusted between 1 and 8. Default value is 4.

4.4.5 Ring Setup

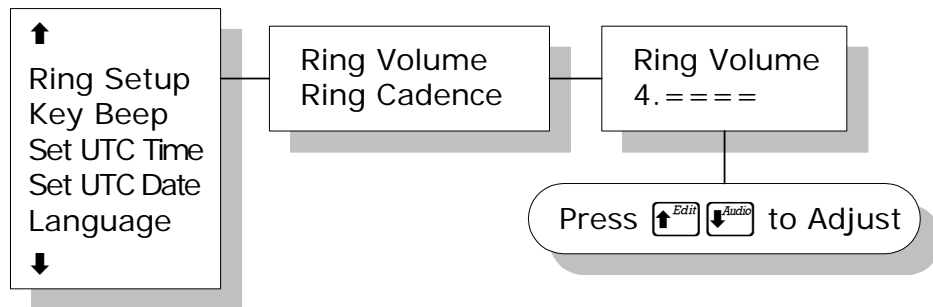

Ring setup gives the possibility to change the ringing tone and the handset volume. Adjustable values are:

Ring Volume: Off|1|2|3|4, default is 4.

Ring Cadence: 1|2|3|4|5|6|7|8, default is 1.

Both settings are adjusted with and .

4.4.6 Key Beep

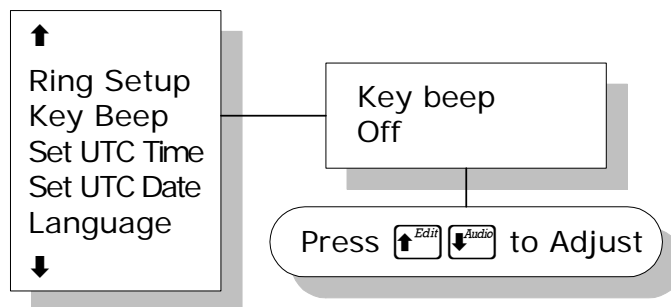

Key Beep, the sound that's heard when a key is pressed, can be set to Off, 1, 2, 3 or 4. The setting is adjusted with and . Key Beep is default off.

4.4.7 Set UTC Time

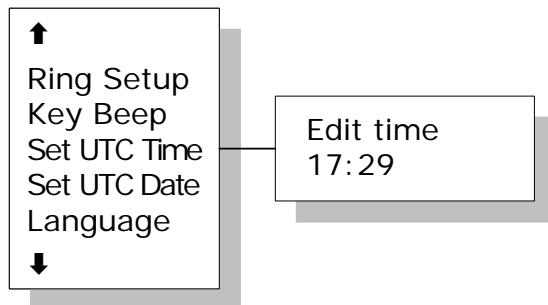

The current UTC time can be viewed and modified. The time is displayed in 24-hour format {hh:mm}. Enter a new time and press **OK** to update or **Exit** to cancel.

4.4.8 Set UTC Date

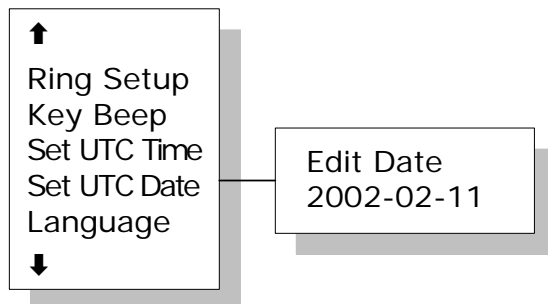

The current UTC date can be viewed and modified. The date is displayed in the format {yyyy:mm:dd}. Enter a new date and press **OK** to update or **Exit** to cancel.

4.4.9 Language

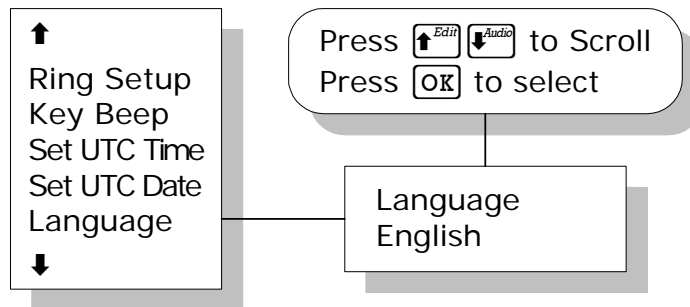

The MMI language can be changed to other languages.

Note: In this release only English can be selected.

4.4.10 Disclose Pos.

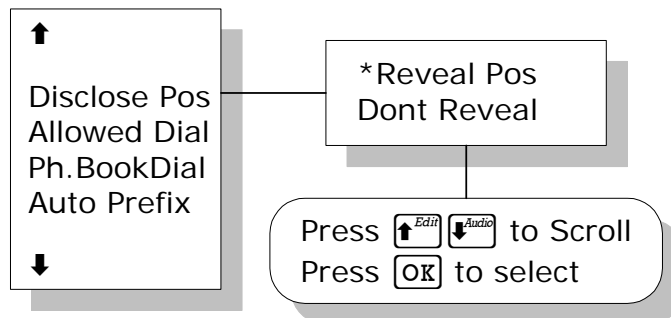

It is possible to disable the automatic reporting of position, from the GPS system. This menu gives the option to change this. Select 'Reveal Pos' or 'Don't reveal' with the [Up Arrow] [Edit] and [Down Arrow] [Audio] key. Select function with the [OK] key. Current status is marked with a *.

Note: Disabling automatic reporting of position, means that the terminal will report spot beam ID instead.

4.4.11 Allowed Dial

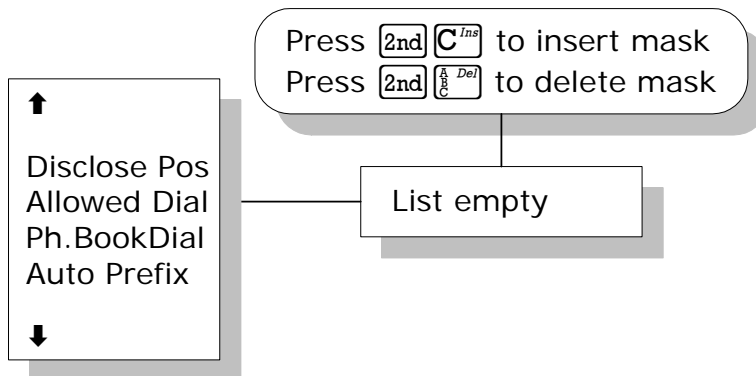

Allowed Dial is a function that allows the Super User to specify a phone number mask, to restrict outgoing calls.

A phone number matches a dial mask, if the number contains at least as many digits as the mask and when the digits in the mask matches the corresponding digits in the phone number, starting from the first digit.

Press **[2nd] [C] Ins** to insert a mask and **[2nd] [A Del] C** to delete an entry.

Examples:

Mask	00453955
Valid number	004539558800
Valid number	004539558888
Invalid number	39558800
Invalid number	004539

The terminal can contain up to 99 entries and each entry can be 22 digits long.

The phone number you enter in the dialer for making an MPDS connection, is a dummy number that is not used. Therefore the "Allowed Dial" list has no effect on MPDS connecting.

4.4.12 Ph.Book Dial

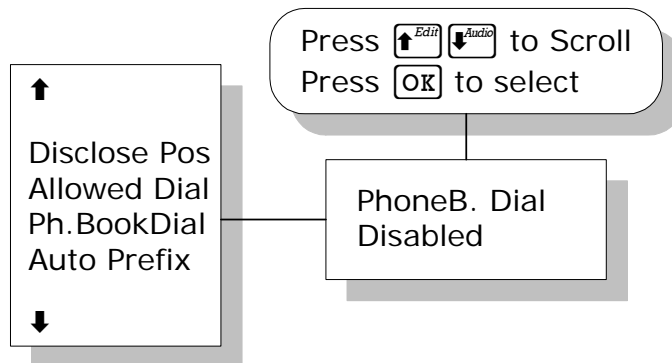

When this function is enabled, Normal User will only be able to make calls using the phone book or the Help desk from a Capsat[®] handset.

Use and to scroll between 'Enable' or 'Disable' and press to select.

The function is by default disabled.

4

4.4.13 Auto Prefix

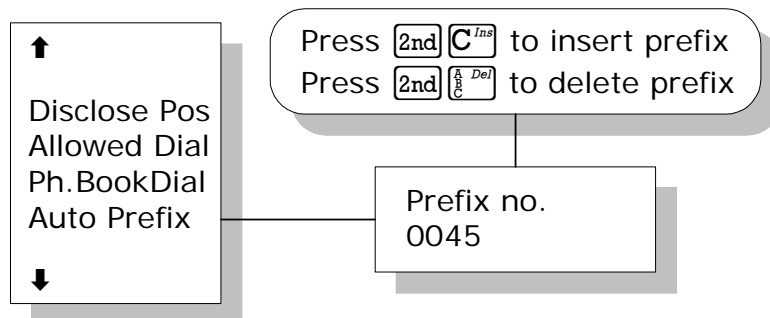

A prefix, e.g. 0045 for Denmark, can automatically be added to any dialed number. The prefix is not added to numbers dialed from the phonebook. One prefix number with up to 22 characters can be defined. By default no Auto Prefix number is specified. Press to insert a prefix and to delete the prefix.

4.4.14 BarServiceIn

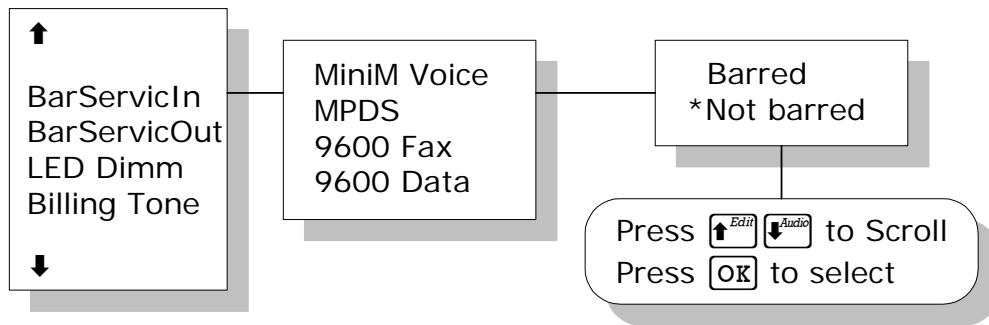

All incoming calls on a specific service can be barred. Scroll through the services with . Select the service with . The service can then be set to 'Barred' or 'Not barred' with and .

4

4.4.15 BarServiceOut

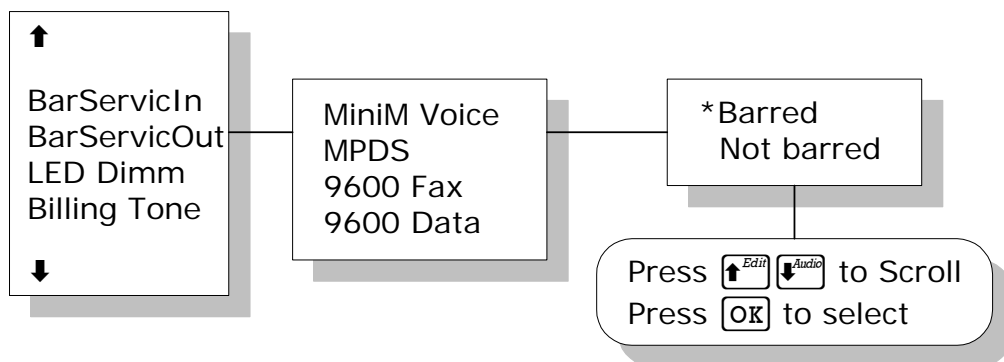

All outgoing calls on a specific service can be barred. Scroll through the services with . Select the service with . The service can then be set to 'Barred' or 'Not barred' with and .

4.4.16 LED Dimm

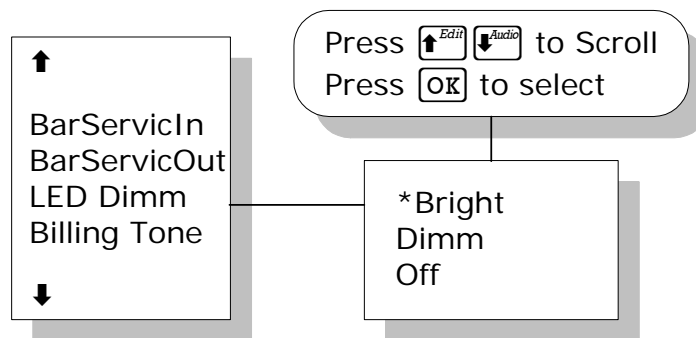

The brightness of the 4 Handset LED's can be adjusted. To change the brightness level, select the **LED Dimm** menu and adjust the value with and . Setting can be adjusted to Bright, Dimm and Off. Default value is Bright.

4.4.17 Ant.Setup

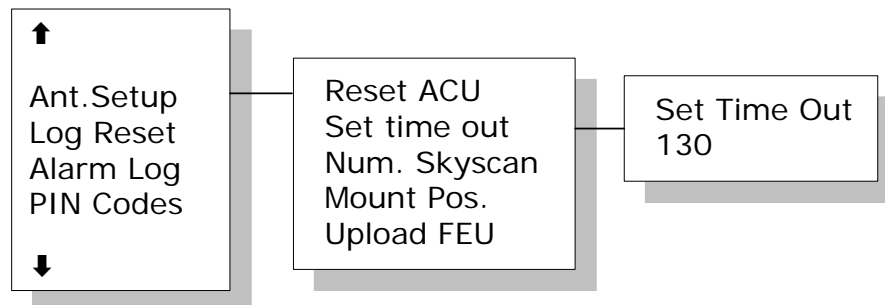

The **Ant.Setup** has got the following sub menus:

Reset ACU: This function will reset the ACU in the antenna. The DC power running in the antenna cable will be turned of for a few seconds, causing the ACU to restart. This can be useful if the antenna control freezes or locks up.

Set time out: This function sets the number of seconds the system waits without a satellite signal before it assumes the tracking is lost. Valid range is 1 to 300

seconds. Default is 130 seconds. Press to validate changes.

Num. Skyscan: Enables the user to define the number of sky scans. Valid range is 1 to 10 scans. Default is 1 scan. Press to validate changes.

Mount Pos.: Because of the build in GPS, the antenna is capable of finding the satellite within a few seconds. A heading of the ship is also needed, but since the GPS does not supply the antenna with this information, a relative angle of the antenna compared to the ships bow, has to be known. Select the antennas mounted position, relative to the ships bow. Valid angles are 0, 90, 180, and 270 deg, positive in a clockwise direction. Default angel is 0 deg. Changes must executed by pressing .

Upload FEU: If a new FEU (Part of the antenna) is installed, this command will upload software to the FEU, thereby pairing the system software with FEU. If the FEU software version in the antenna is different from the version that is stored in the system, you will get a warning. You may then use the "Upload FEU" command to remove this difference.

4.4.18 Alarm

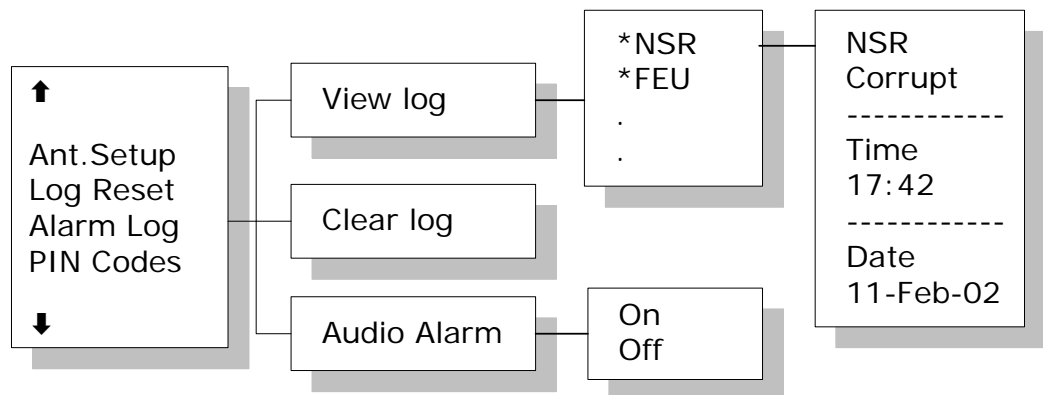

The **Alarm Log**, logs all the alarms in the system. From this menu, the alarm can be viewed and cleared. To clear the alarm list, select the submenu "Clear alarms" and confirm the message "Delete all?" by pressing **OK**. Scroll through the alarm list, using the **↑** Edit **↓** Audio keys. A * in front of the Alarm name, indicates that the alarm is still active. Select an alarm for viewing, by pressing **OK**. Each entry for an alarm contains an alarm description and the time and date when the alarm occurred. See section 6.1 for a list of alarms.

The alarm log can contain up to 20 entries. The log will wrap around when the log is full.

You may get an audio alarm when an alarm is added to the alarm log. This may be turned on and off by entering the Audio Alarm menu.

4.4.19 PIN codes

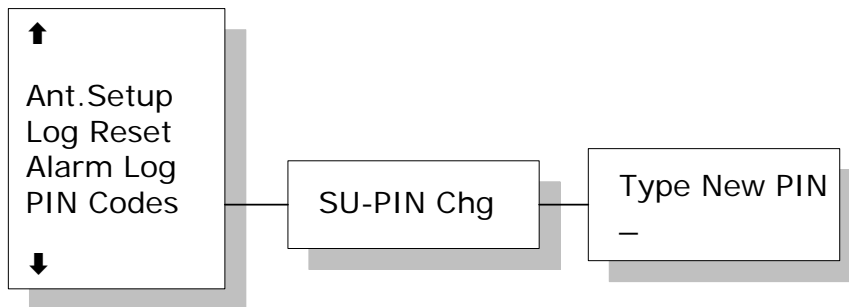

The **PIN codes** menu is where the Super User PIN is changed. For a description of the pin codes, see section 3.2 Use of PIN Codes. The **PIN codes** menu has the following sub menu.

SU-PIN Chg: The Super User PIN is changed here. Type the new PIN and press **OK** to accept the change.

4

4.4.20 Routing

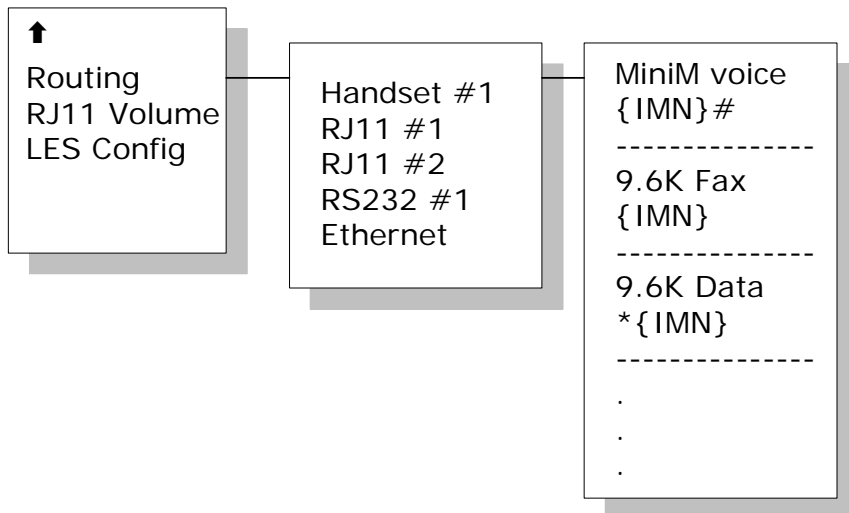

This menu has been divided into a submenu pr. interface plus a print menu:

- Handset #1

- RJ11 #1
- RJ11 #2
- RS-232 #1
- Ethernet

Note 1: The IMN-number has to be defined, before the service can be routed to an interface. The service will not be listed in the routing table, unless it has an IMN-number defined.

Note 2: Some users want the IMN number to reflect the corresponding telephone number. In this case the user should EDIT the default IMN number. The INSERT function is only for adding additional IMN numbers (or for creating the first IMN in case the list is empty).

When entering one of the above submenus it is possible to scroll through a list of all relevant IMN-numbers for the interface. In the handset menu, you will see all IMN's associated with voice: i.e. mini-M voice. If an IMN has an incoming route to an interface it is marked with "*". If it has an outgoing route to an interface, it is marked with a "#". It is possible to change the routing-status for each IMN to the opposite by pressing * for incoming and #^{Dim} for outgoing.

It is possible to route one IMN to more interfaces. E.g. an IMN can be routed to both RJ11 interfaces at the same time. This will make it possible, to have an incoming call being routed to two 2-wire phones simultaneous.

4.4.21 RJ11 Volume

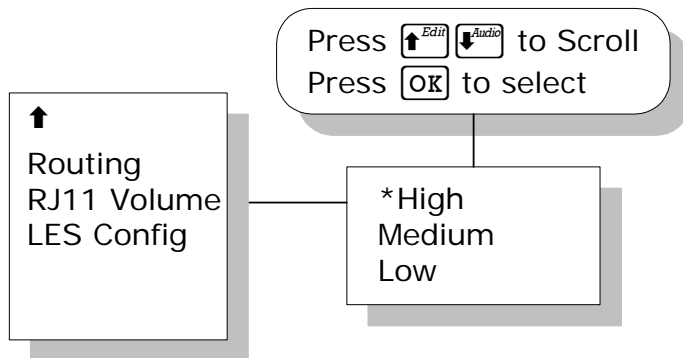

2-wire phones, connected to the RJ11 interfaces, may vary in sensitivity. The output volume from the interfaces can therefore be adjusted. The volume can be set to **High**, **Medium** or **Low**. The setting is adjusted with *Edit* and *Audio* and selected with . The default value is **High**.



4

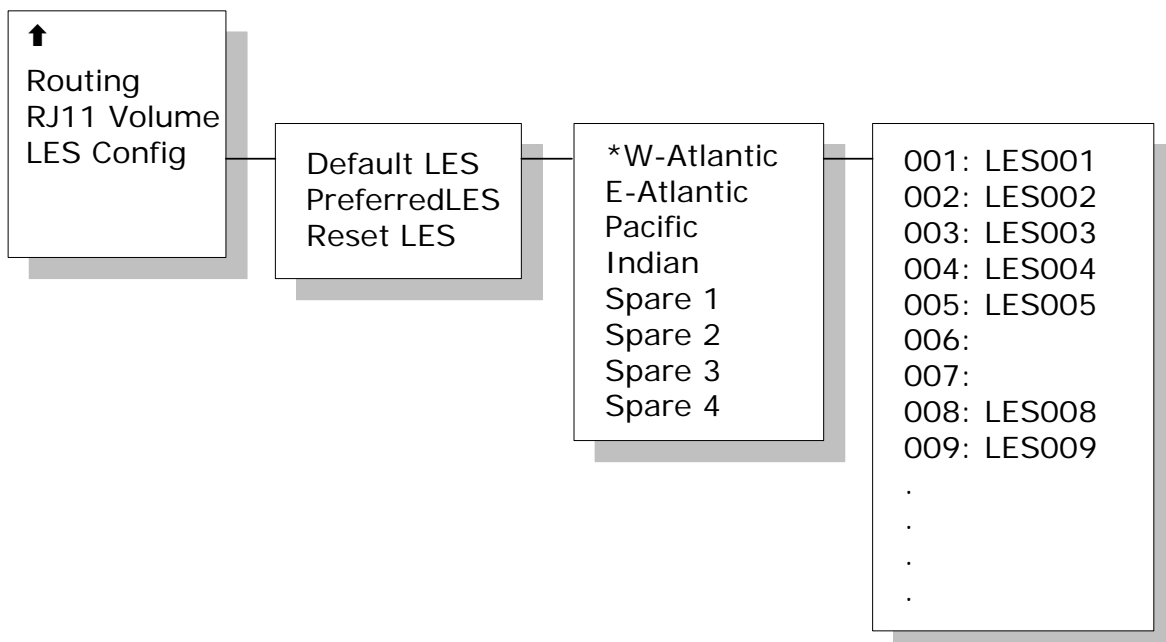



4.4.22 LES Config









This menu is used to select a list of LES operators. It contains the following sub menus:

- Default LES
- PreferredLES
- Reset LES

The **Default LES** list contains a list of those LES operators, which may be selected as gateway to the terrestrial network. The last used LES will be marked with * and this LES will also be the first LES tried next time the terminal is logged on. If there's no LES list selected under Allowed or Preferred LES, the Default LES list will contain the LES list from the satellite bulletin board, meaning all available LES in the selected Ocean region. Use   and  to select a Ocean region and then a LES.

You may also edit the LES names in the "Default LES" list. Press   to start editing the selected name. You may clear the name by pressing  .

An **Allowed LES** list can be selected under the Service User menu. If an Allowed LES list exists, only the LES's in this list can be selected under Default and Preferred LES. An Allowed LES list contains all available LES operators in the selected ocean region. Those operators marked with * can be used as Default LES operators and thus appears in the Default LES list above. If all LES operators are allowed and can be used there are no markings.

As there are many operators, you can use **PreferredLES** to make selections easier. The Preferred LES list can be used to indicate in which order LES operators should appear on the Default LES list. This is done by pressing   for each LES intended to be on the list and in the order they should appear in the Default LES list. Press  to update the preferred LES list. To remove a LES from the list, press   and then  to update the list.

The **Reset LES** command reset all the LES names to default names.

5 PC Programs

5.1 System Set-up from PC

System set-up can be managed from a PC program called FleetCP, instead of from the handset. The following pages are a short introduction to FleetCP. The picture below shows the initial screen, when the program is started.

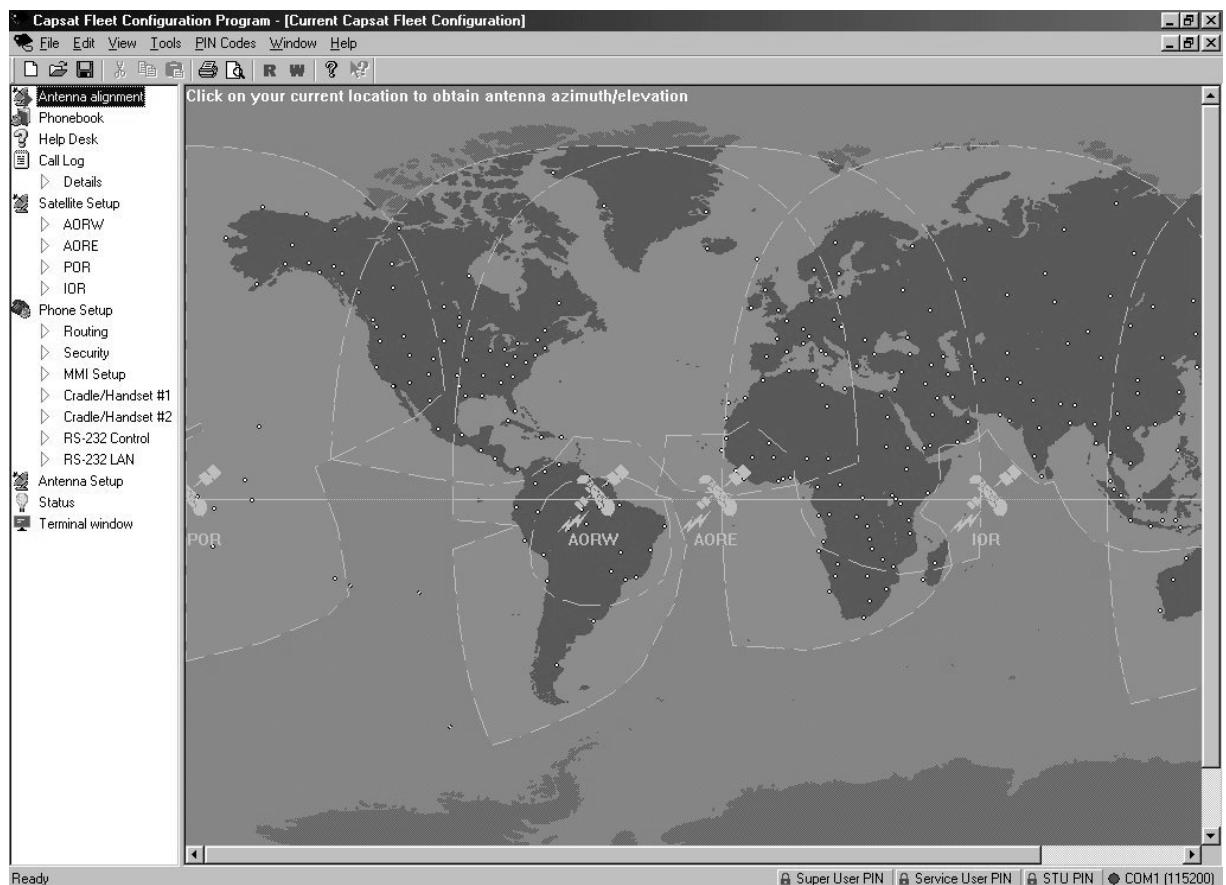

Clicking the red **R** button on the top toolbar, will read the current configuration from the terminal. Clicking the red **W** button, will write any changes to the terminal.

The functions can be selected by clicking in the left menu window. The menu window is divided into the groups, Antenna alignment, Phonebook, Help Desk, Call Log, Satellite Setup, Phone Setup, Antenna Setup, Status and Terminal window.

Clicking the map will show the Azimuth and Elevation to the satellites reachable in that area. See picture below.

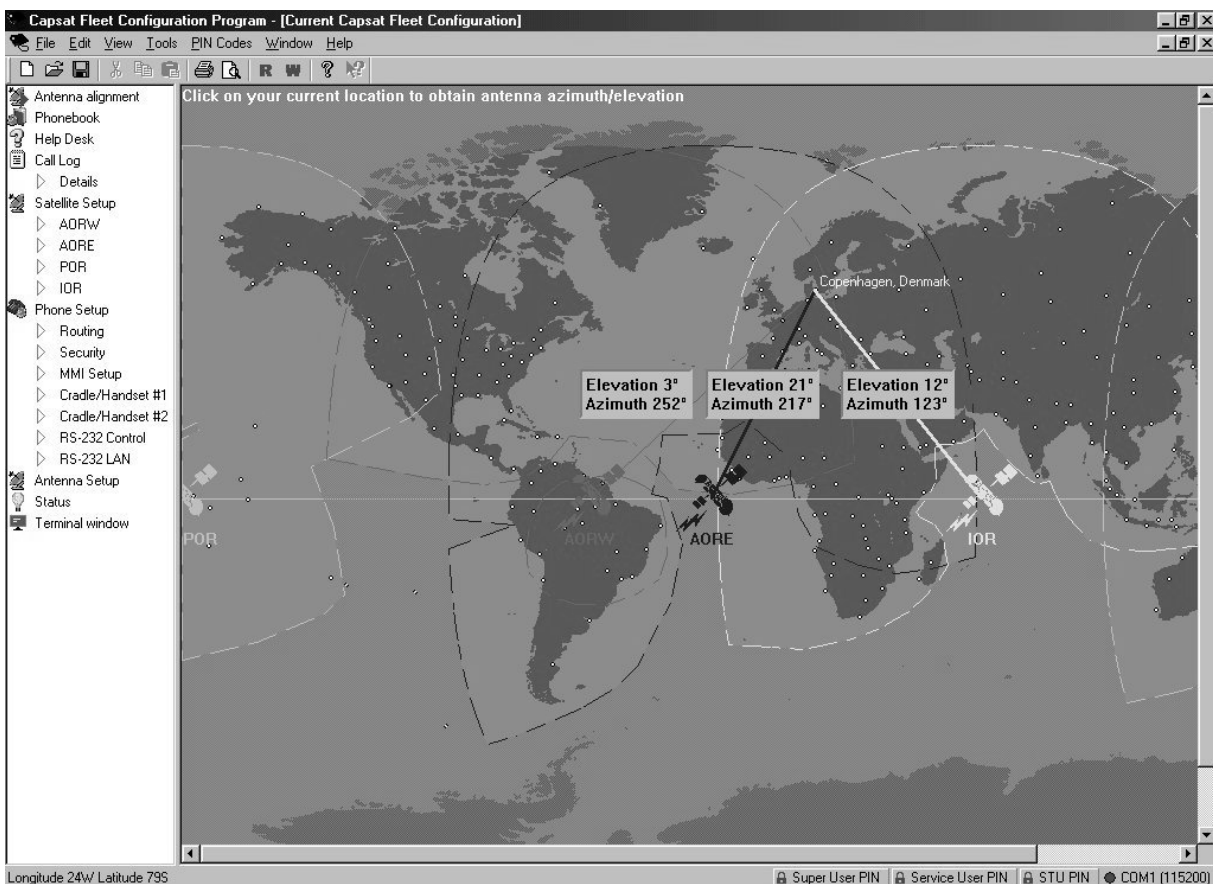

The status bar in the lower part of the window will show longitude and latitude as the cursor is moved around the screen.

The status of the PIN codes can be seen on the right side of the status bar. If no PIN codes are entered, all locks will be red and locked. Click the appropriate button to enter or change a PIN code. See picture below. If a PIN is entered,

the lock will become unlocked and turn green. At the same time a new logout button will appear next to the PIN code buttons. Clicking this button resets the status of the all PIN codes.

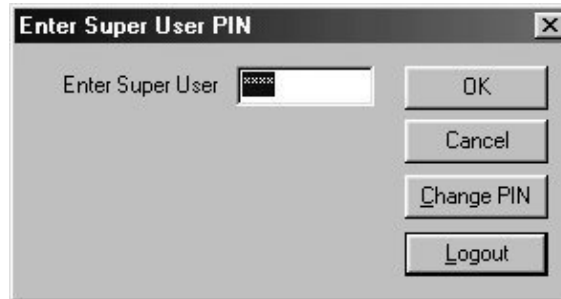

If a change to the configuration is made without entering a PIN code first, a prompt will appear when the write button is pressed, asking for the PIN. See below.



To read more about PIN codes see section 3.2 Use of PIN Codes.

The phonebook entries are made by selecting **Phonebook** and right clicking in the phonebook area. Entries here can be modified or deleted in the same way. See picture below. Further information can be found 4.3.1 Phonebook.

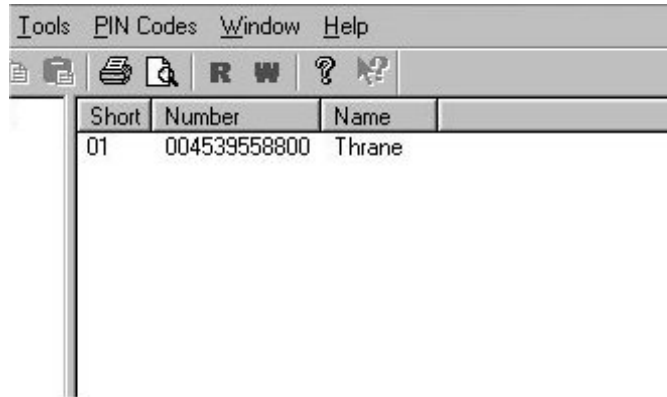

The screenshot shows a window titled 'Tools PIN Codes Window Help'. Below the title bar is a toolbar with icons for file operations and editing. The main area contains a table with the following data:

Short	Number	Name
01	004539558800	Thrane

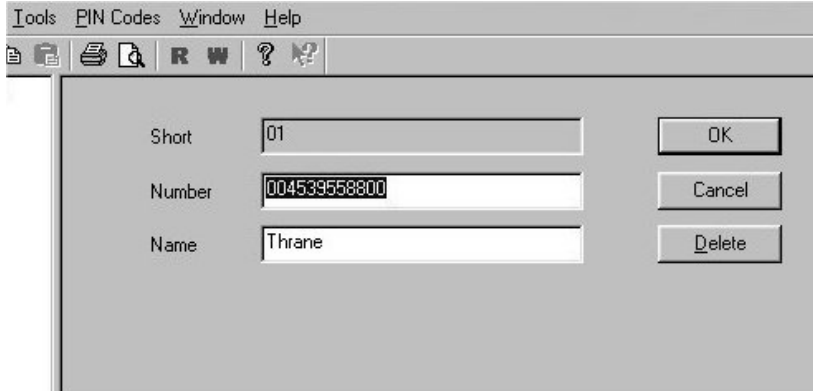

The screenshot shows the same window with an edit dialog box open. The dialog box has three input fields and three buttons:

Short	<input type="text" value="01"/>	<input type="button" value="OK"/>
Number	<input type="text" value="004539558800"/>	<input type="button" value="Cancel"/>
Name	<input type="text" value="Thrane"/>	<input type="button" value="Delete"/>

Help Desk entries are inserted, edited or deleted in a similar way. Please refer to the Installation Manual for further information.

Satellite Setup offers an easy way of setting up Allowed, Preferred and default LES. LES operators are dragged and dropped between the three tables. Setup is made for each ocean region. See below.

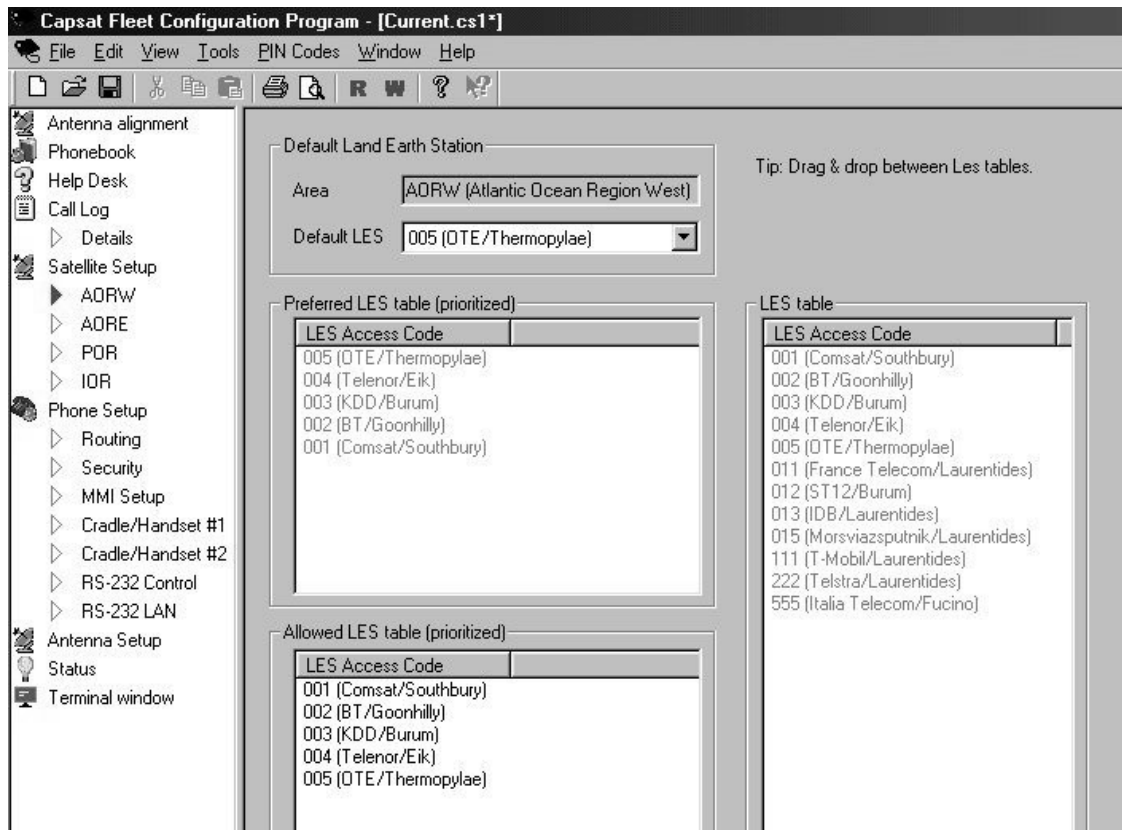

Read more about LES configuration in section 4.4.22 LES Config.

Use the table in the **Routing** window to route calls. Click in the cell that corresponds to service/interface that is to be changed. Click the * or # button in lower part of the screen to define it as an incoming or outgoing call. To add an IMN, click the New IMN/ID button (see picture below).

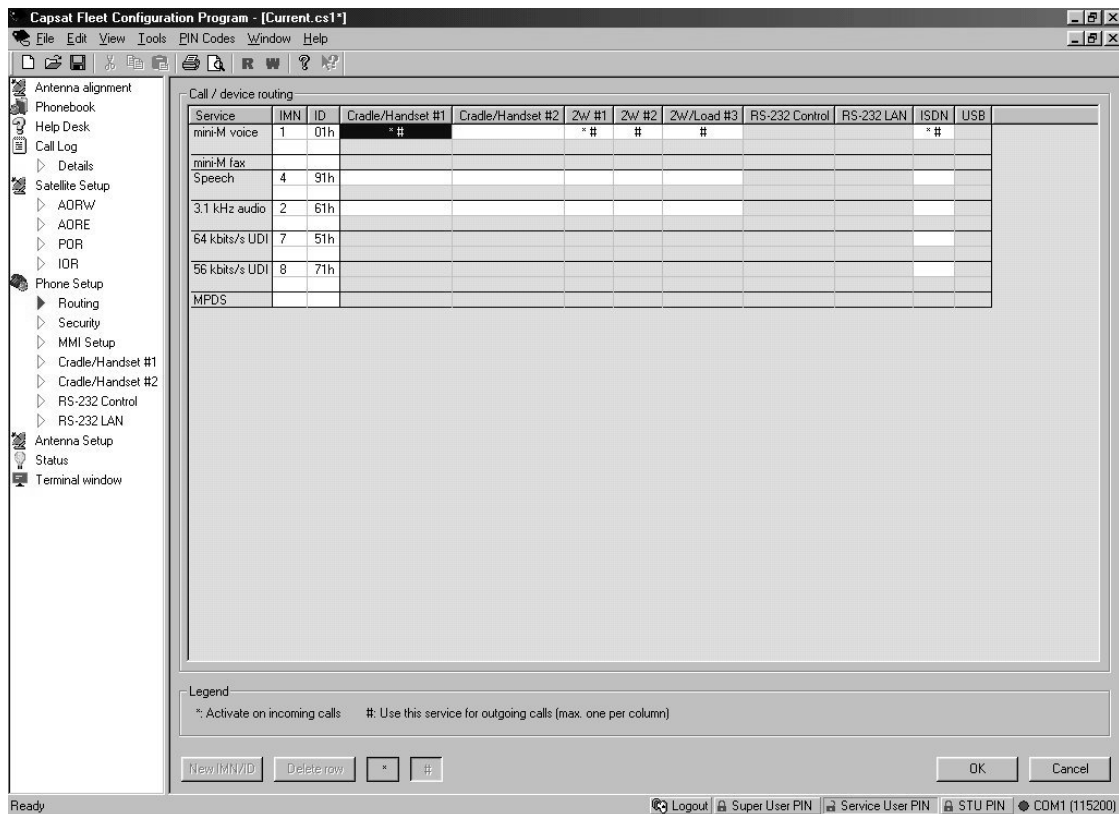

See section 4.4.20 Routing and IMN Config in the Installation manual for a detailed explanation about routing, IMN and ID's.

In the **Security** window call restrictions can be enabled or disabled and an Auto prefix inserted.

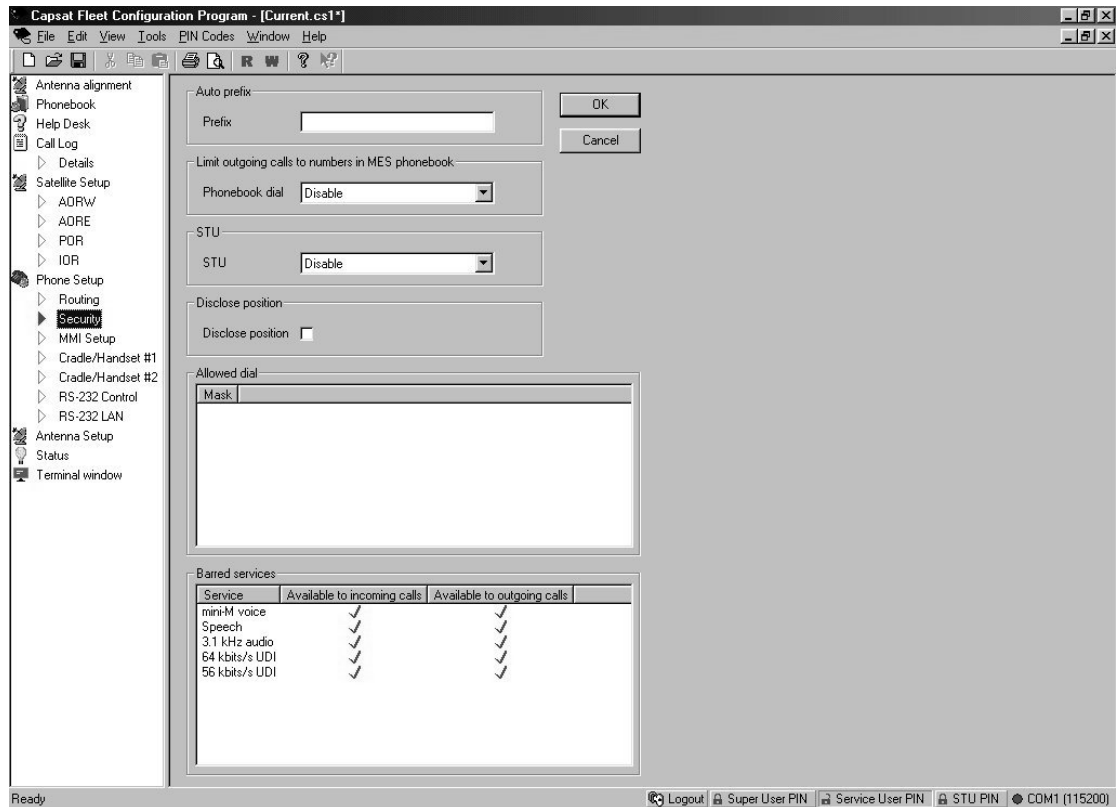

See section 4.4.11 Allowed Dial, 4.4.14 BarServiceIn and 4.4.15 BarServiceOut for more details.

The **MMI setup** window can be used to correct the time/date or in the future, the language.

Click the **Use PC time** button to import the time and date from the PC clock (see picture below).



The **Cradle/Handset** window is where the ring type, ring volume, LED brightness and display contrast, is adjusted.

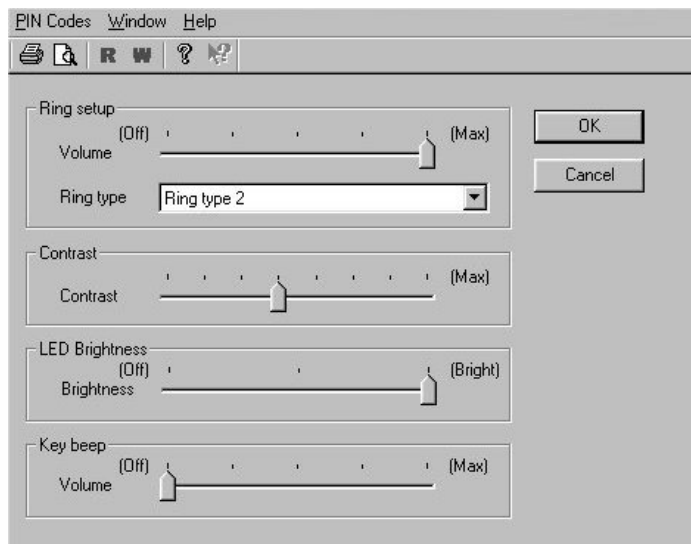

RS-232 parameters of the terminal can be changed in the **RS-232** window.

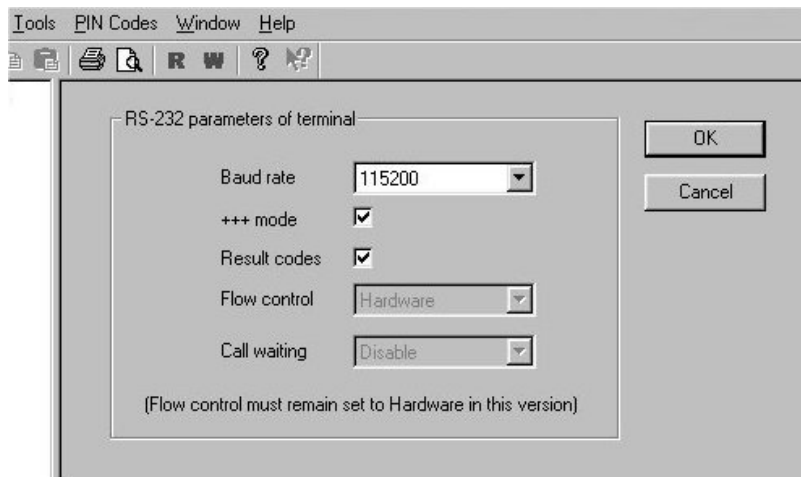

The **Antenna setup** gives a possibility to change Long term failure timeout, number of allowed sky scans and the antennas mount position relative to the ships bow. See section 4.4.17 Ant.Setup for details. The antenna can be rebooted by clicking the Reset ACU button.

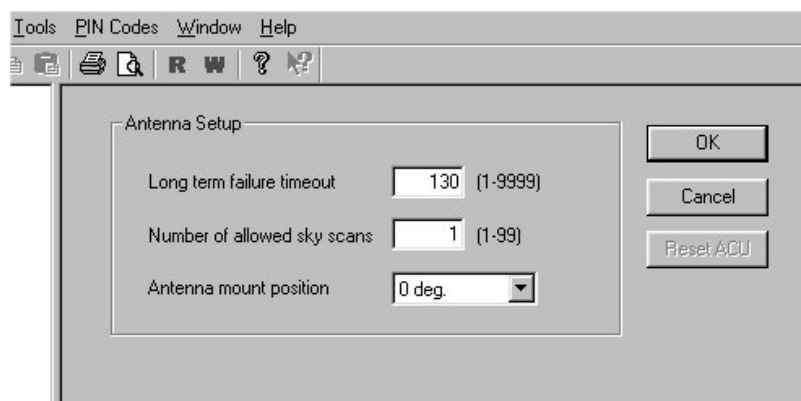

The **terminal window** makes it possible to run AT commands in the same way as the Windows program HyperTerminal.

5.2 Set-up Using RS-232

The illustrations below shows a typical hardware setup for a MPDS or 9.6 kps data connection using the RS-232 interface.



MPDS or 9.6 kps data Hardware Connection.

For a MPDS or 9.6 kps data session, connect a RS-232 cable between the COM port of the computer and the RS-232 interface on the Fleet system.

5.2.1 Set-up for MPDS

The TT-3088A transceiver is connected to a PC or similar equipment via a standard RS-232 cable. In this manual, the setup of a PC running a MS-Windows operating system is described.

Configuring the TT-3088A

The transceiver has to be configured for the right ocean region and LES operator that provides the MPDS service. This is done using the TT-3088A handset user interface.

The transceivers RS-232 configuration shall be (using the handset user interface):

- Baud Rate: 115200 baud
- Flow control: Hardware

Setting up your PC

In this section the setting up of a MS-Windows based PC is described in general terms covering Windows 95, 98, 2000 and NT. The screen dumps below is from Windows 98. For a detailed description with more screen dumps of the installations, you are referred to the Application Note "Configuring Capsat Fleet77 for MPDS" on your MES Software distribution disk or at our web site WWW.TT.DK.

Step 1: Install a standard modem

- From the Control Panel select Modems and add a Standard modem. Do not let Windows detect the modem, but manually choose a standard 28800 bps Modem.
- Select the appropriate COM port (i.e. the COM port that is connected to the TT-3088A serial port).
- Set maximum speed to 115200
- Set Data bits = 8, Parity = None and Stop bits = 1

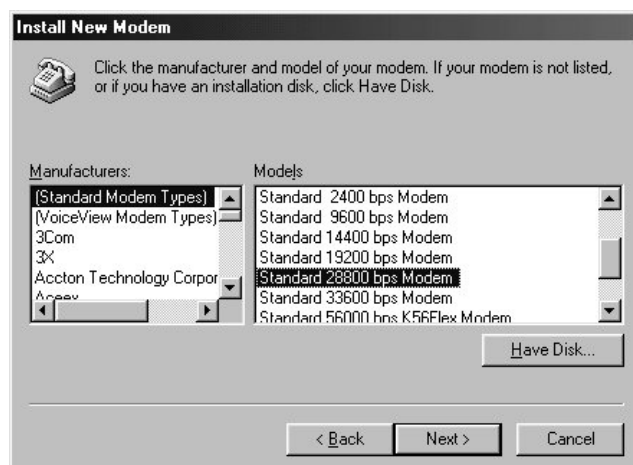

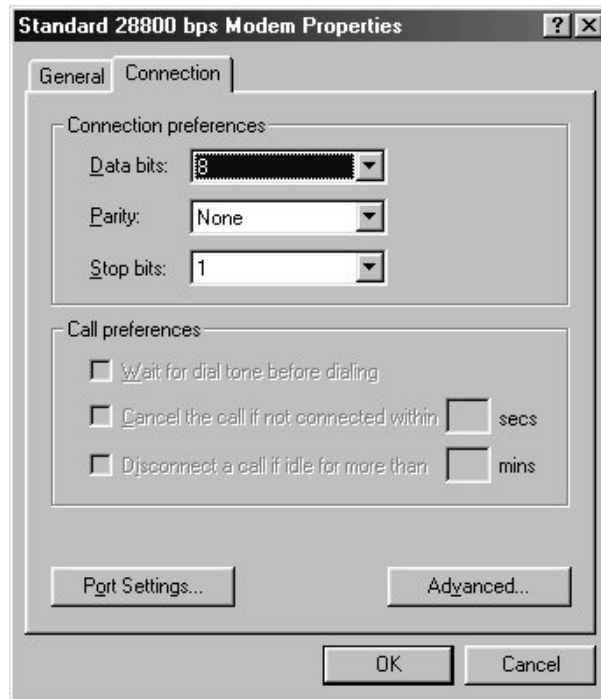
**Important:**

- Enter Advanced settings and type the initialization command `AT+WS45=4` in the Extra settings field. This string is transferred to the TT-3088A transceiver when setting up a connection. If the MPDS connection is to use another LES than the one already selected, you use the initialization command = `AT+WS45=4; +WLES=XXX`, where XXX is the LES number.
- If the terminal is to stay in MPDS mode with no activity, for longer periods of time, then the automatic “disconnect when idle” setting in Windows must be disabled. Refer to your Windows manual on how to do this.

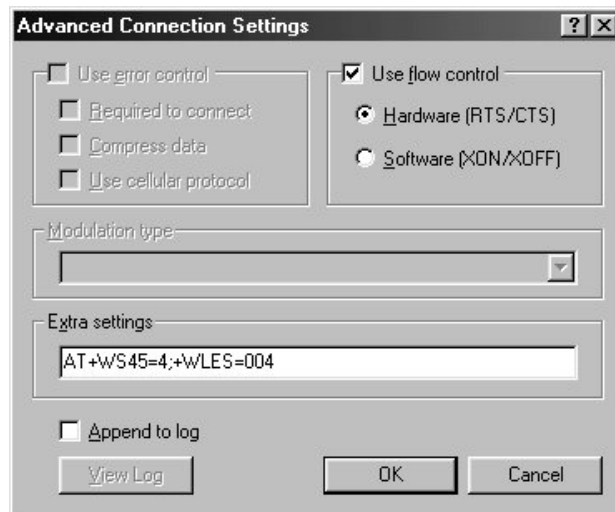

Step 2: Create a Dial-up connection

Open Dial-up Networking from My computer. Click "Make new connection"

- Select the standard modem defined during step 1 as the dial up device
- Enter a dummy telephone number (the number is not used but has to be defined – write e.g. "123" as the phone number)
- Give the connection a recognizable name e.g. MPDS connection

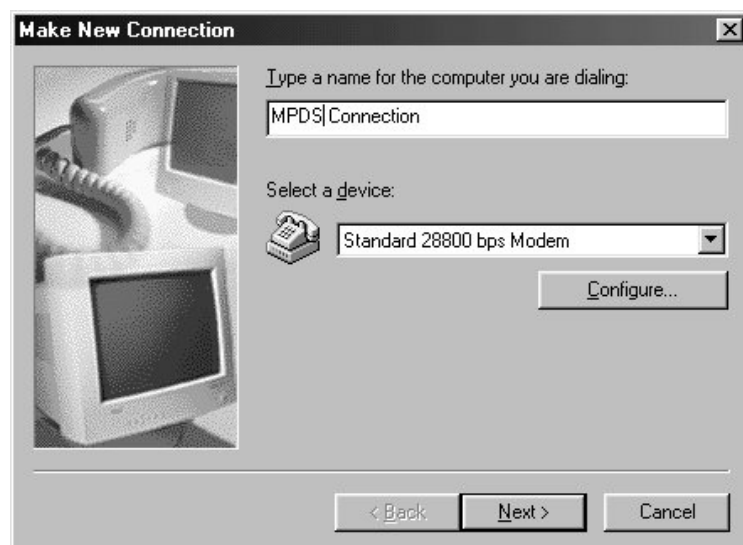

Include TCP/IP as allowed network protocol and use default TCP/IP settings (Server assigned IP address, Server assigned name server addresses etc.)

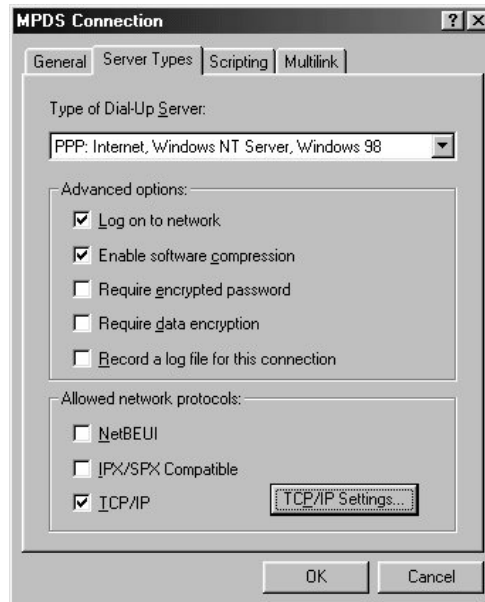

5

5.2.2 Set-up for 9600 Data

The correct routing has to be configured via the handset. See section 4.4.20 Routing on how to route the data interface.

In the example below, is shown how to setup an Internet connection via 9.6K data interface.

Step 1: Install a modem

- From the Control Panel select Modems and add a modem.
- Let Windows detect the modem automatically.

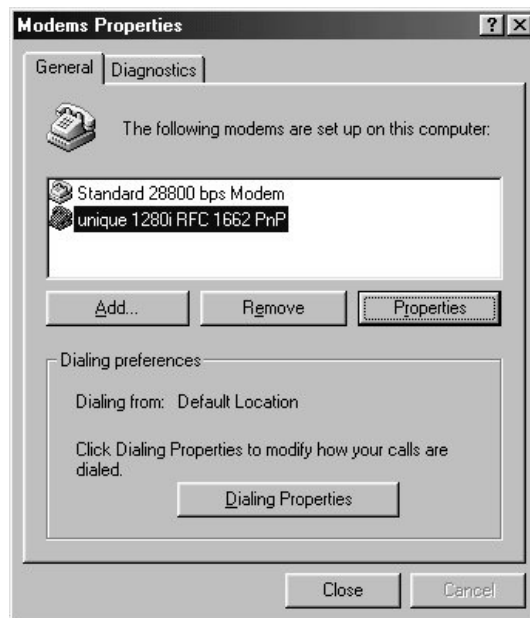
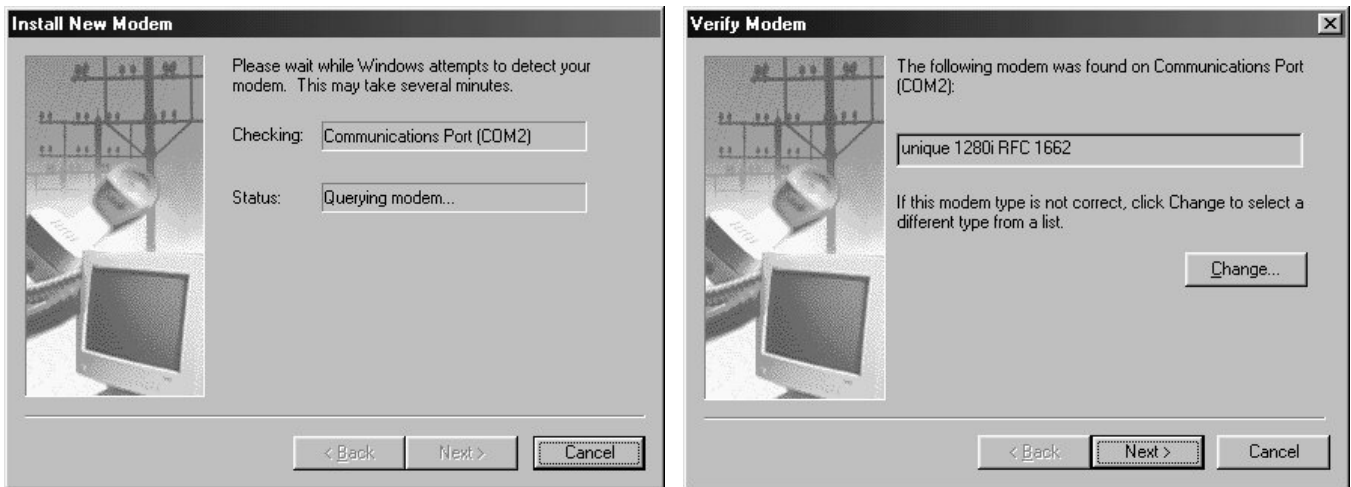

Step 2: Create a Dial-up connection

Open Dial-up Networking from My computer. Click "Make new connection"

- Select the Lasat modem defined during step 1 as the dial up device
- Enter the telephone number to the Internet Service Provider. Remember country code and area code if necessary.

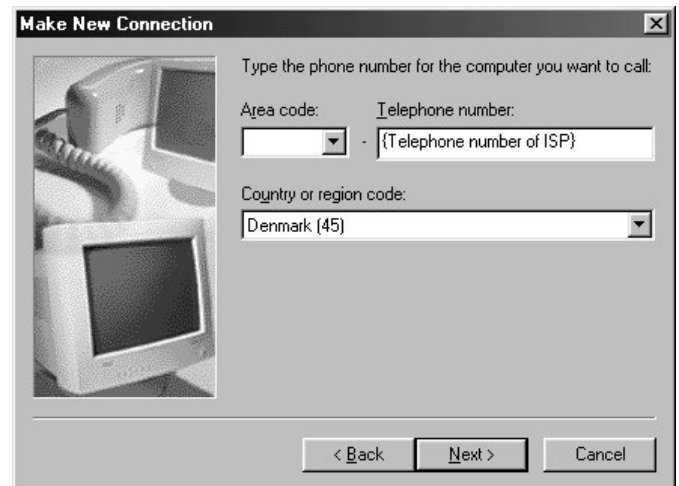

- Give the connection a recognizable name e.g. ISDN connection

Include TCP/IP as allowed network protocol and use TCP/IP settings (Server assigned IP address, Server assigned name server addresses etc.) as recommended by the ISP.

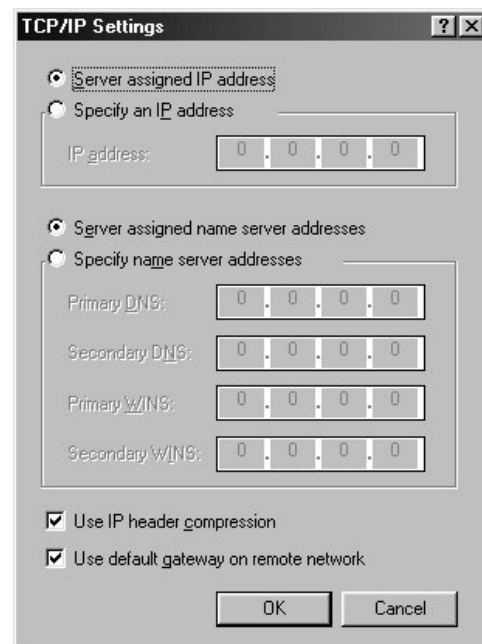
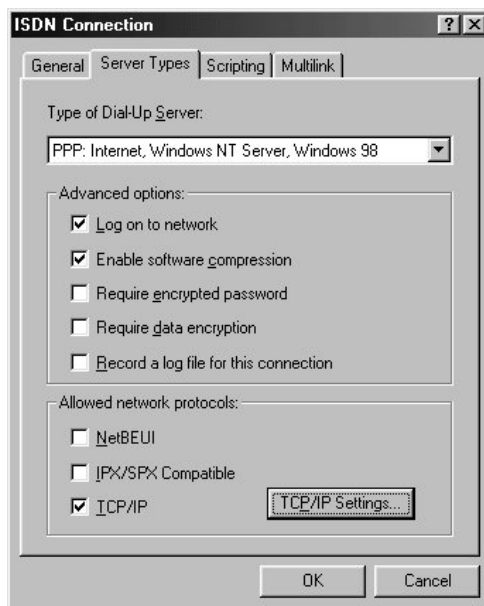

After this the connection can be made as described in section 3.4.1 MPDS Connection.

5.3 Set-up using Ethernet/PPPoE

This chapter describes the set-up and operation of data connections via Ethernet and PPPoE using various PPPoE clients.

5.3.1 Windows XP with Built-in PPPoE Client

Prerequisites

The PC must have an Ethernet adapter and Windows XP installed and both must be operational. There must be a network connection between the PC and the Capsat® F33 system.

Setting up the Connection

1. From the "Start" menu select "Settings" then "Network Connections" and then "Create New Connection". This brings up the "New Connection Wizard".
2. Click "Next".
3. Select "Connect to the Internet" and click "Next".
4. Select "Setup my connection manually" and click "Next".
5. Select "Connect using broadband connection requiring user name and password" and click "Next".
6. Type a name for the connection, e.g. "MPDS via PPPoE" and click "Next".
7. Select "Anyone" and click "Next".
8. Type a random user name and password and click "Next".

9. Select the shortcut on desktop option.
10. Click "Finish".
11. Now click the new shortcut on the desktop named "MPDS via PPPoE". The Capsat® F33 system should now make the connection.

Note:

Because of the relatively long set-up time for a data connection, the PPPoE connection may some times time out.

5.3.2 Win2000 with WinPoET™ PPPoE Client

(Tested under MS Windows 2000)

The data connection via Ethernet and PPPoE can be established using various PPPoE clients. For this example WinPoET client was used.

Prerequisites

The computer must have a working Ethernet adapter.

Windows Dial-Up Networking (DUN) must be installed.

Installation

The WinPoET program is contained in a self-extracting zip-file.

1. Double click the icon, and installation begins.
2. Click 'OK' and 'Next' a few times to accept license agreement and accept rebooting the computer (only older windows versions.)
3. To make the first connection with WinPoET, click the start button, and find the new program folder 'iVasion'.

- In 'iVasion', press 'WinPoET' and 'WinPoET dialer'.



- Enter random user name and password and then click connect.

The status field tells you how far you have reached in the connection process.

The phases of a successful connection are:

- Click Connect to start the connection process.
- Connecting to communications device.
- Starting authentication process.
- Starting projection phase.
- Authentication completed successfully
- Connected

After the first connection, WinPoET creates a 'WinPoET Connection' in the 'Network and dial-up connections' folder that can be used with the standard Windows DUN system (Automatic dialling and disconnection etc.).

6 Troubleshooting

6.1 List of Error messages

6.1.1 Satellite Network Messages

Within the satellite network a number of messages are defined to indicate the network status. This section describes the possible messages (Cause Codes) that might be displayed in the TT-3620G Handset.

Cause Code	Description	Event
1001	Normal (not shown in the handset)	MES is clearing the call as instructed by the relevant MES terminal equipment.
1011	Called party is busy.	MES is rejecting the call because the specified MES terminal number is currently busy, and MES has not been authorized to divert calls which are addressed to that number
1012	Called party is busy	MES is clearing the fixed-originated call because subsequent to the acceptance of the call and the signaling of the identity of the mobile terminal to which the call will actually be routed, that terminal has become busy and hence cannot be rung
1021	No User	MES is clearing the call because

Cause Code	Description	Event
	responded	appropriate "off-hook" signaling has not been received from the addressed MES terminal (including any authorized diversions) within the allowed time limit
1081	Identified channel does not exist	MES is rejecting the call because the specified MES terminal number has not been installed, and MES has not been authorized to divert calls which are addressed to that number
1091	Destination out of order	MES is rejecting the call because the specified MES terminal number is currently out-of-service, and MES has not been authorized to divert calls which are addressed to that number
1092	Destination out of order	MES is clearing the fixed-originated call because subsequent to the acceptance of the call and the signaling of the identity of the mobile terminal to which the call will actually be routed, that terminal has become out-of-service and hence cannot be rung
1141		Call cleared, MES initiated pre-emption
1142		Call cleared, MES initiated pre-emption
1143	Preemption	MES is prematurely clearing the fixed-originated call which is in the process of being established because the MES user has initiated a call from a terminal which is authorized to automatically preempt an existing fixed-originated call

Cause Code	Description	Event
1144	Reserved	
1145	Preemption	MES is prematurely clearing the mobile-originated call which is in the process of being established because the MES user has initiated a call from a terminal which is authorized to automatically pre-empt an existing mobile-originated call
1146	Normal.	MES is prematurely clearing the mobile-originated call which is in the process of being established because the MES user has abandoned the call (by placing the originating terminal "on-hook")
11A0		LES is clearing the call because the credit card being used is not valid (at this LES) for calls to the country indicated in the "service address" information received from the MES
11D1	Inconsistency in designated outgoing access information and subscriber class.	LES is rejecting the call because the "Service Nature" and/or "Service Type" and/or "Channel parameter" information received from the MES is invalid (e.g., not currently defined in the SDM, mutually contradictory, or not applicable to a MES-originated call)
11D2	Invalid number format (address incomplete)	LES is clearing the call because the "service address" information received from the MES is invalid (i.e., less than 2 digits)

Cause Code	Description	Event
11D3	Protocol error, unspecified	LES is clearing the call because the "service address" information received from the MES is a 2-digit address which is either undefined or which is currently unavailable at this LES
11D4	Protocol error. Unspecified	LES is clearing the call because "credit card data" information received from the MES is invalid. [This does not imply that the credit card itself is invalid]
11D5	Protocol error, unspecified	LES is clearing the call because the "service address" information received from the MES contains a country code which is regarded (by this LES) as invalid
11D6	Inconsistency in designated outgoing access information and subscriber class.	LES is clearing the call because the "PID" information received from the MES in the "scrambling vector" message (type 8DH) is not consistent with the PID information in the Fixed/MES-Originated (PID) and PID/MES Registration Tables at the LES as it relates to this call.
11D7		
11D8		
11E0		LES is clearing the call because the credit card PIN received from the MES is not considered (at this LES) to be valid.
11E1		LES is clearing the call because it has been determined that an excessive number of consecutive call attempts with

Cause Code	Description	Event
		invalid credit card PINs have been made
1201	Reserved	
1261	Reserved	
1262		Call cleared, MES time-out (Distress Test exceeded 120s)
1281	Channel type not implemented	MES is rejecting the call because the MES is not equipped to provide the specified service
1291	Requested circuit/channel not available.	MES is rejecting the call because although it is equipped to provide the specified service, it is not currently able to do so
12B1	Interworking. Unspecified	MES is rejecting or clearing the call for a reason which is not covered by any of the currently defined "Cause" events
12C1		Call failed, MES time-out (no scrambling vector ack)
12C2	Protocol error. Unspecified	MES is clearing the call because a "credit card valid" message (type A7H) has not been received by the MES within the allowed time limit
12C3	No response from terrestrial side	MES is clearing the call because a "LES Connect" message (type 8CH) has not been received by the MES within the allowed time limit

Cause Code	Description	Event
12C4	Protocol error. Unspecified	MES is clearing the call because the "authentication query" ISU message (type B4H) and/or the "authentication query" SSU message (type B5H) have not been received by the MES within the allowed time limit
12C5	Protocol error. Unspecified	MES is clearing the call because an expected supplementary services SU(s) has(have) not been received by the MES within the allowed time limit
12C6	Protocol error. Unspecified	MES is clearing the call because the "supplementary services interrogation" ISU (type B2H), and/or "subscriber digits" SSU (type ADH) messages have not been received by the MES within the allowed time limit
12C7	Protocol error. Unspecified	MES is clearing the call because a "SCPC channel release" SU (type 8AH) has not been received by the MES, in response to the transmission of a "notification acknowledge" message (type BAH) during the supplementary services call diversion information retrieval process, within the allowed time limit
12D1	Protocol error, unspecified.	LES is rejecting the call because the "spot-beam ID" information received from the MES is invalid (i.e., ID is not allocated on satellite in use)
12D2	Protocol error.	LES is clearing the call because the "Scrambling Vector" information received

Cause Code	Description	Event
	Unspecified	from the MES is invalid (ie,0000H, 6959H or 7FFFH)
1351		MES is clearing the call because the MES currently has insufficient free memory in which to store the short message
1361	Temporary failure	MES is clearing the call because the Above-decks equipment is about to "cable unwrap"
1362	Recovery on timer expiry.	MES is clearing the call because a long-term interruption in reception has occurred (the definition of a "long-term interruption" depends upon the service type, see Section B)
1363	Preemption	A Secondary Functional Center of a Multi-channel MES is clearing the call because the Primary Functional center has commanded the Above-decks equipment to repoint to a different Ocean Region
1392		Call cleared, spot beam transition
1451	No circuit/channel available.	LES is rejecting the call because an appropriate terrestrial circuit is not currently available at this specific LES
1452	No circuit/channel available.	LES is rejecting the call because an appropriate channel unit and associated terrestrial circuit are not currently available at this LES. [This "cause" is only utilized when there is a permanent "one-to-one" connection between appropriate

Cause Code	Description	Event
		channel units and their terrestrial circuits]
1541		Call cleared, pre-empted at LES
1551		LES is rejecting the call because an appropriate satellite channel is not currently available at this specific LES
1552	Reserved	
1581	Requested circuit/channel not available.	LES is rejecting the call because the requested service is not provided by this specific LES
1591	Temporary failure.	LES is rejecting the call because the requested service is temporarily not available at this specific LES
1592		LES is clearing the call because the specified credit card type is not currently supported by this specific LES
15A1	Bearer capability not authorized	LES is rejecting the call because the specified MES is not authorized for any service at this specific LES
15A2	Bearer capability not authorized	LES is rejecting the call because the specified MES is not authorized to use specific requested service via this specific LES
15A3		LES is clearing the call because the "credit card data" information received from the MES has been rejected by the credit card

Cause Code	Description	Event
		authorization process
15A4		LES is clearing the call because the data received from the MES in the "authentication reply" message (type B6H) has been declared "invalid" by the LES authentication process
15A5	Bearer capability not authorized	LES is rejecting the call because the specified PID is not authorized for any service at this specific LES
15A6	Bearer capability not authorized	LES is rejecting the call because the specified PID is not authorized to use specific requested service via this specific LES
15A7		
15B1	Interworking. Unspecified	LES is rejecting or clearing the call for a reason which is not covered by any of the currently defined "Cause" events
15C1	Protocol error, unspecified	LES is rejecting the call because an appropriate "Channel Assignment" message has not been received by the LES within the allowed time limit
15C2	Protocol error. Unspecified	LES is clearing the call because the "service address" information has not been received by the LES within the allowed time limit
15C3	Protocol error, unspecified	LES is clearing the call because a "Scrambling Vector" message (type 8DH)

Cause Code	Description	Event
		has not been received by the LES within the allowed time limit
15C4	Protocol error. Unspecified	LES is clearing the call because neither the "service address" information nor a "Scrambling Vector" message (type 8DH) has been received by the LES within the allowed time limit
15C5	Protocol error. Unspecified	LES is clearing the call because the complete "credit card data" information has not been received by the LES within the allowed time limit
15C6	Reserved	Call failed, LES time-out (return carrier identifier)
15C7	No answer from user (user alerted)	LES is clearing the call because a "MES Connect" message (type 99H) has not been received by the LES within the allowed time limit
15C8	Reserved	
15C9		LES is clearing the call because a "authentication reply" message (type B6H) has not been received by the LES within the allowed time limit
15CA		LES is clearing the call because a "notification acknowledge" message (type BAH) has not been received by the LES within the allowed time limit
15CB		LES is clearing the call because the

Cause Code	Description	Event
		request sequence number contained in the received "notification acknowledge" message (type BAH) is not valid (i.e. either not '0' or not the next value in the sequence)
15D1	Message with unrecognized parameter, discarded	LES is rejecting the call because the "Channel Assignment" message received from the NCS contains inappropriate or conflicting information
15D2	CES → NCS Signaling only.	LES is clearing this MES ID and channel number in the busy lists at LES and NCS because a new call to/from this MES is being set-up (and thus any previous call to/from this MES must have cleared)
15E1	Preemption - circuit reserved for reuse	LES is attempting to clear an MES which has sent an SCPC channel release message but is found still to be transmitting 5.12 s later
1651	No circuit/channel available.	LES is rejecting the call because an appropriate channel unit is not currently available at this specific LES
1661	Recovery on timer expiry	LES is clearing the call because of an interruption in reception of the MES carrier exceeding the allowed time limit
16C1	Reserved	
16C2	Recovery on timer expiry	LES is clearing the call because an appropriate SCPC MES carrier has not been received by the LES (at the

Cause Code	Description	Event
		commencement of the call) within the allowed time limit
1790		LES is clearing the call because of a malfunction in the credit card validity checking database or in the communications links thereto
1791		LES is clearing the call because of a malfunction in the authentication checking database or in the communications links thereto
1811	Called party is busy	NCS is rejecting the call because the specified MES ID is in the "MES busy" list at the NCS.
1841		Call cleared, NCS initiated preemption for incoming Pri 1 call
1842		Call cleared, NCS initiated preemption for incoming Pri 2 call
1843		Call cleared, NCS initiated preemption for incoming Pri 3 call
1844		Call cleared, NCS initiated channel preemption
1851	No circuit/channel available.	NCS is rejecting the call because an appropriate SCPC channel is not currently available
1852		

Cause Code	Description	Event
1853		
1854		NCS is rejecting the call because the MES is outside the spot beam coverage area
1855		Call rejected, preemption failed, no channel available
1856		Call rejected, spot beam selection failed
18A1	Bearer capability not authorized	NCS is rejecting the call because the specified MES ID was not found in the "Forward and Return MES ID" cross-reference table
18A2		NCS is rejecting the call because the MES is outside the spot beam coverage area
18A3		NCS is rejecting the call because the specified LES is not authorized for the requested service at the NCS
18B1	Interworking, unspecified	NCS is rejecting or clearing the call for a reason which is not covered by any of the currently defined "Cause" events
18B2		
18C1	Subscriber absent	NCS is rejecting the call because no message was received from the specified MES (in reaction to a Call Announcement message) within the allowed time limit
18D1		

Cause Code	Description	Event
18E1	Called Party is busy	NCS is rejecting the call because the specified MES ID is in the "MES busy" list at the NCS, and is listed as being busy with a call through the same LES as that now requesting a "call announcement" addressed to that MES
18E2		
18E4		
18E5		
1C61		
1F01	Normal (not shown in the handset)	LES is clearing the call because of the receipt of "on-hook" signalling from the relevant terrestrial circuit.
1F11	Called Party is busy	LES is clearing the call because the terrestrial called party is engaged (busy)
1F21	No User responded	LES is clearing the call because appropriate "off-hook" signalling from the terrestrial called party has not been received by the LES within the allowed time limit
1F61	Destination out of order	LES is clearing the call because of the detection of a failure in the relevant terrestrial circuit
1F62	Normal	The LES is clearing the call because the terrestrial calling party or the terrestrial network has cleared the call before the

Cause Code	Description	Event
		"MES connect" message has been received by the LES.

6.1.2 TT-3088A Messages

Alarm Type	Alarm Message
Transceiver Alarms	Tx-Level Not Ok.
	1. LO Lock Not Ok.
	2. LO Lock Not Ok.
	3. LO Lock Not Ok.
	Vtune Alarm.
	Invalid position information received from GPS.
	MSR Corrupt
	MIR Corrupt
	MIDR Corrupt
	NAR Corrupt
	NSR Corrupt
	SVR Corrupt

Alarm Type	Alarm Message

Antenna Alarms	Antenna(FEU), Wrong Type, Check Conf.
	Antenna(FEU) Link Down, Check Cable
	FEU Reset, Powered Down
	FEU Reset, Sleep Mode
	FEU Error, To Follow
	FEU Status, heat alarm
	FEU Status, burst alarm
	FEU Status, power alarm
	FEU Status, reset
	FEU Version Mismatch, Try Upload
	ACU Comm, Failure
	ACU Reset, Powered Down
	ACU Reset, Sleep Mode
	ACU Error, To Follow
	Kernel Error, Float point

6

	Kernel Error, Control task overrun
	Kernel Error, SCI tsk overrun
	Memory Error, Control SW CRC
	Memory Error, ACU Cnf Data
	Memory Error, ACU Cal CRC
	Memory Error, FLASH mem
	Memory Error, ACU SRAM
	Memory Error, ACU EEPROM
	Motor Error, Azm Drive
	Motor Error, Elv Drive
	Motor Error, Azm Winding
	Motor Error, Elv Winding
	Pos feedback, Azm Zero Ref
	Sensor Err, Roll Incl
	Sensor Err, Pitch Incl
	Sensor Err, Roll Rate
	Sensor Err, Pitch Rate
	Sensor Err, Yaw Rate

	Sensor Err, Roll attitude our of range
	Sensor Err, Pitch attitude out of range
	Sensor Err, Inclinator meas. out of range
	Ctrl Logic, ACU Matrix inversion error
	Ctrl Logic, ACU resett.
	Ctrl Logic, Floating point error type and address
Handset Alarms	Handset COM Error ¹

6

¹ This error means that the communication between handset and transceiver has stopped for some reason. It does not need to be an error caused by the handset, but it may be cause by errors in e.g. transceiver, antenna, and connection cables.

7 Index

- 2nd functions 18
- 64 kbit/s 27
- Abbreviations 1
- ACU 51, 67
- ADU 6
- Alarm 14, 38, 79
- Alarm Log 38, 53
- Antenna 6, 51, 67
- Area 34, 35
- AT commands 67
- Azimuth 60
- Barring 50, 65
- Baudrate 44, 69
- BDU 7
- Brightness 51, 66
- Bulletin board 57
- C/No 39
- Call log 42
- Calling the terminal 26
- Connectors 9
- Contrast 44, 66
- Country code 5
- Data setup 44
- Dataflow 44
- Date 46, 66
- Dial-Up networking 27, 28, 71
- Discrete I/O 9, 10
- Display symbols 13
- Elevation 60
- Email 27
- Fax 30
- File transfer 27
- FleetCP 59
- Function buttons 15
- Geo-stationary 3
- GPS 6, 47
- Handset 6, 8, 11, 54
- Help Desk 37
- IMN 5, 55, 64
- Inmarsat 3
- Internal calls 31
- International access codes 26
- Internet Explorer 27
- IP/LAN 27
- ISDN 68
- ISN 39
- ISP 5
- Key Beep 45
- Language 47, 66
- LED 51
- LES 35, 57, 63
- LESO 3
- Mailbox 36, 41
- Mask 48
- Menu 32
- Microwave iii
- Mounting position 52, 67
- MPDS 4, 27, 68
- NCS 3
- Normal User 24, 31
- Ocean region 34, 57
- Outlook Express 27
- Phonebook 29, 32, 62
- PIN code 24, 37, 54, 60
- Position 47
- Power 14

Index

- Power button..... 21, 24
- Prefix 25, 49, 65
- PUK code 25
- Redial..... 29
- Ring setup 45, 66
- Ringing tone..... 45
- RJ11 8, 9, 29, 30, 31, 55
- Routing 55, 64
- RS-232.. 8, 10, 44, 55, 67, 68
- Satellite..... 3
- Service User..... 25, 31
- Setup using Ethernet & PPPoE
..... 75
- Short code 29, 33
- Short message 36, 41
- Sky scans 52, 67
- Software version..... 39
- Spot-beams 3
- Status 39
- Super User..... 24, 31
- Synchronization..... 14
- Time 46, 66
- Time out..... 51, 67
- Transceiver unit..... 6
- Volume 45, 66
- Web browsing 27
- Windows 2000 and PPPoE . 76
- Windows XP and PPPoE..... 75

Appendix A - Menu Tree

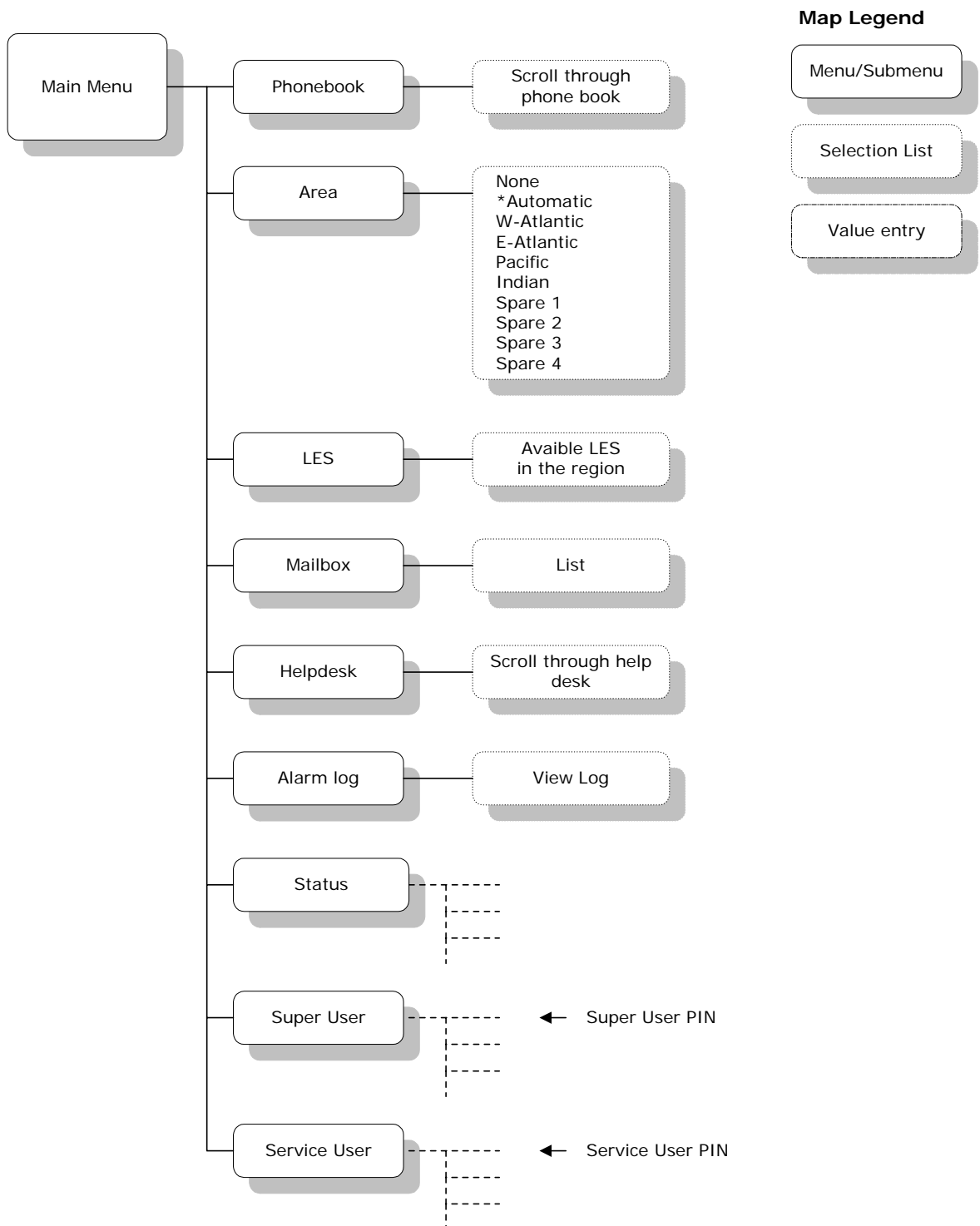

Appendix A - Menu Tree

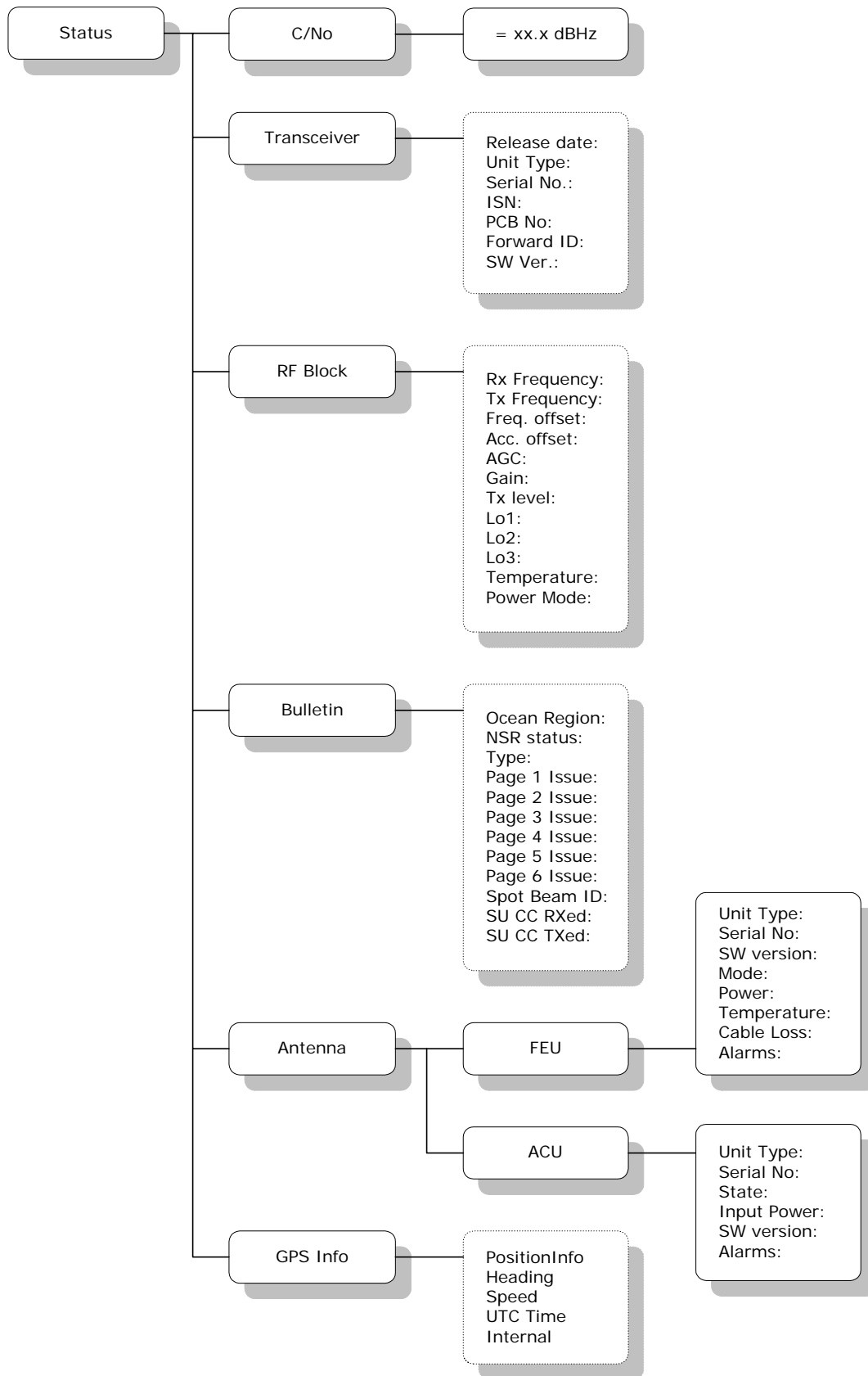

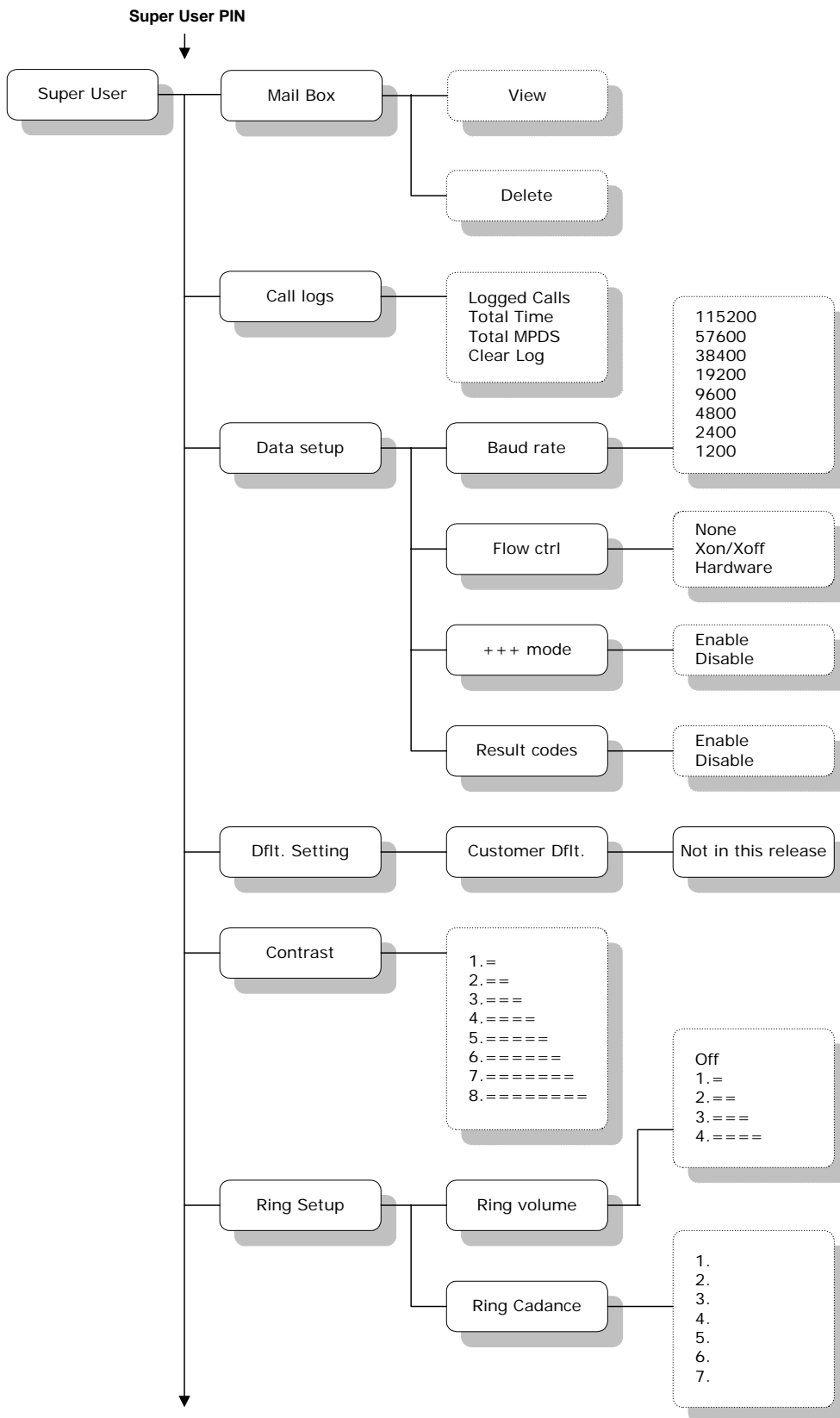

Appendix A - Menu Tree

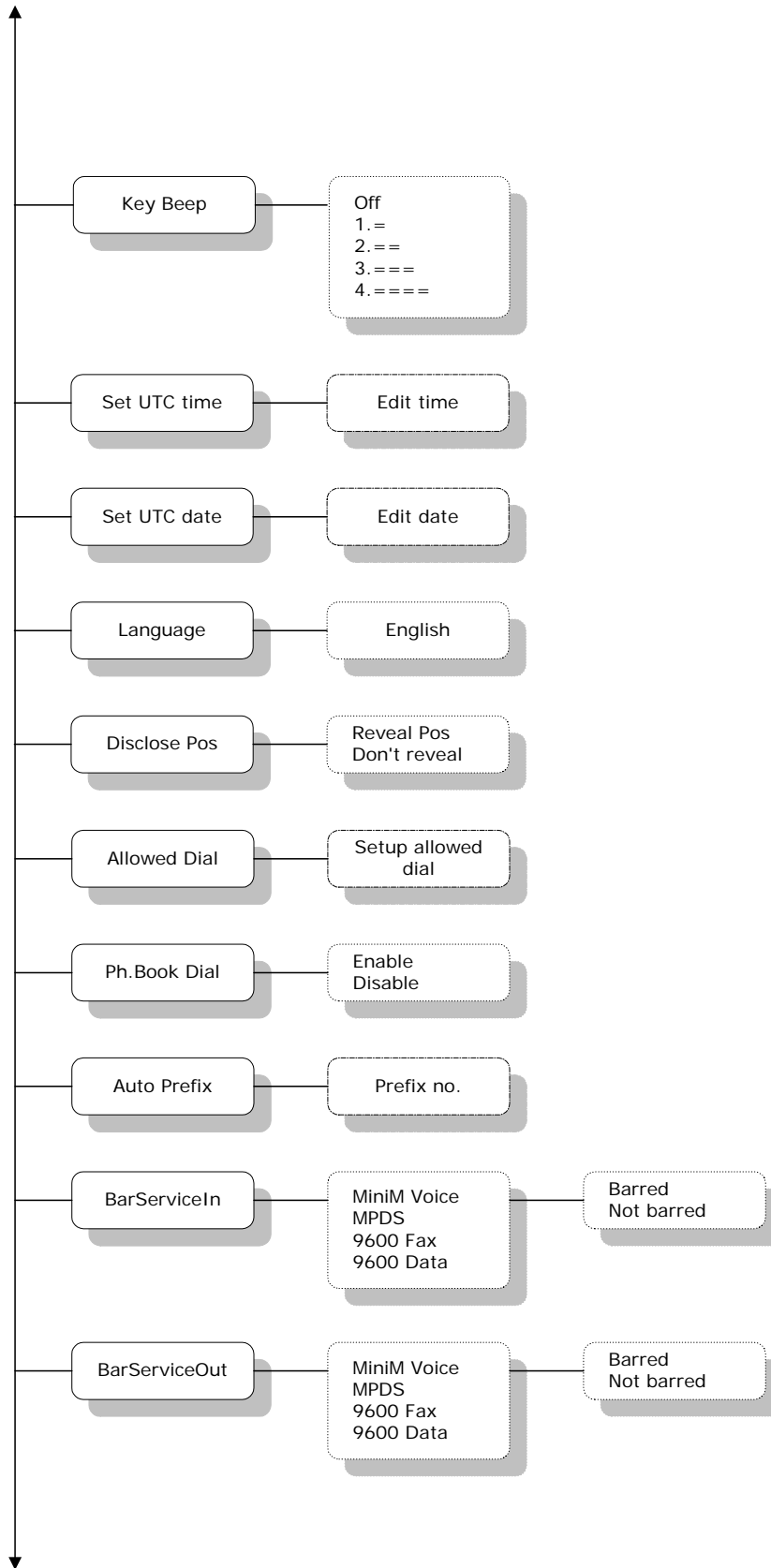

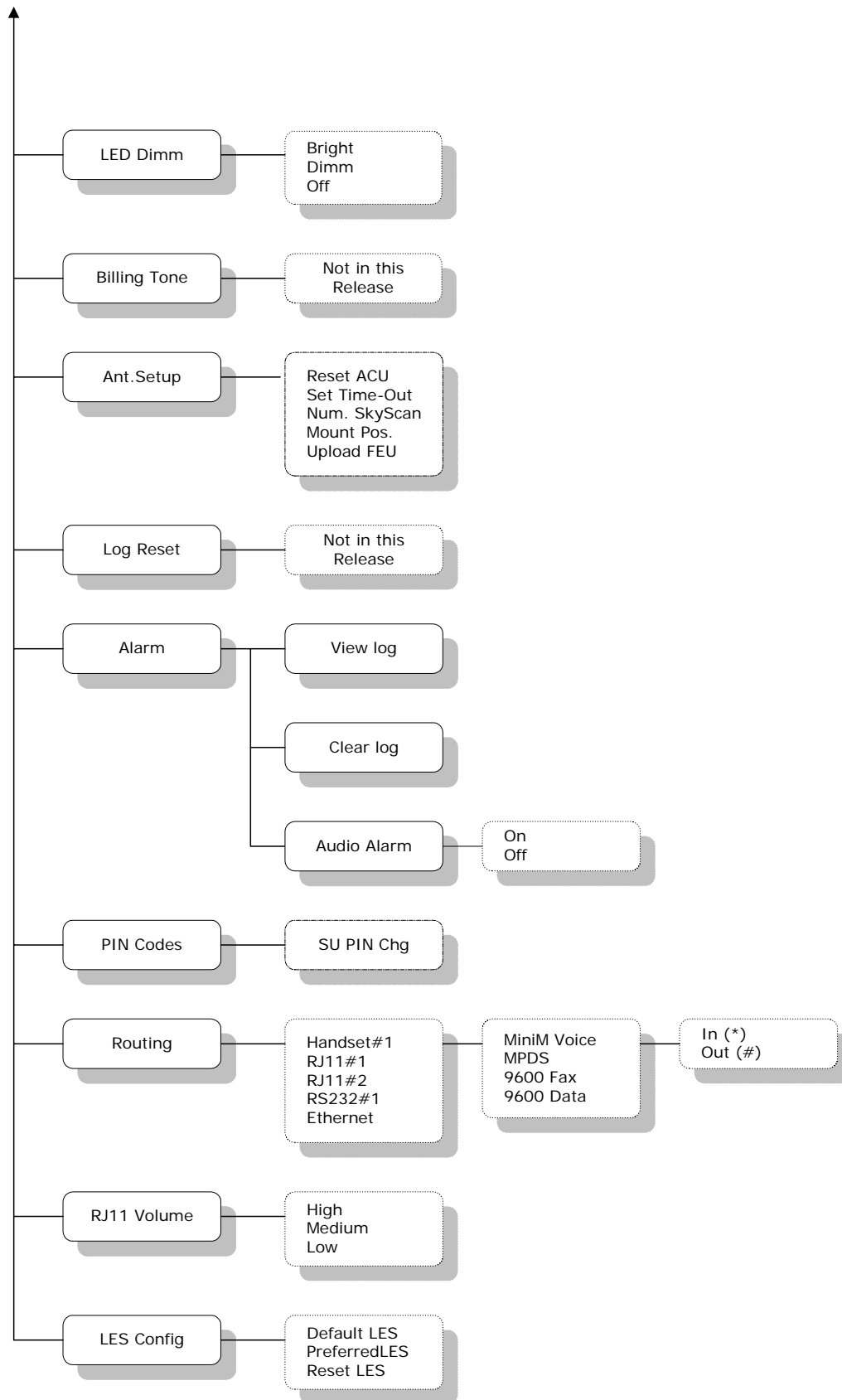

Appendix A - Menu Tree

